

340 West HWY 291, Salida, CO 81201

CITY OF SALIDA

CONSTRUCTION

STANDARDS AND SPECIFICATIONS

WATER, SANITARY SEWER, STREET

Compiled by the Salida Public Works Department
Drawings & Technical support by Schmueser, Gordon, & Meyer Engineering
August 2010

RESOLUTION NO. 49
(Series 2010)

**A RESOLUTION OF THE CITY COUNCIL OF THE CITY OF SALIDA,
COLORADO, ADOPTING THE CITY OF SALIDA REVISED STANDARDS
AND SPECIFICATIONS FOR CONSTRUCTION**

WHEREAS, the Salida Municipal Code currently includes, as Chapter 11, Streets, Sidewalks and Parkways; and

WHEREAS, the Chapter 11 of the Municipal Code references the City of Salida Standards and Specifications as the governing document for construction; and

WHEREAS, the 2010 revisions to the Standards and Specifications ensures that new construction is uniform and in compliance with ADA requirements; and

WHEREAS, the City Council has found that the Standards and Specifications is consistent with other provisions of the code and preserves the public health, safety, general welfare and contributes to the orderly development of the City.

NOW, THEREFORE, BE IT RESOLVED BY THE CITY COUNCIL FOR THE CITY OF SALIDA, COLORADO that the City of Salida Standards and Specifications for Construction 2010 is hereby approved.

RESOLVED, APPROVED AND ADOPTED this 7th day of September, 2010

CITY OF SALIDA

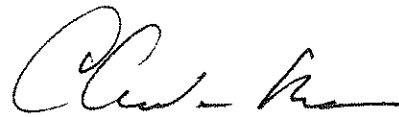

Charles Rose, Mayor

[SEAL]

ATTEST:



Betty Schwitzer, City Clerk

CITY OF SALIDA
WATER MAINS, SANITARY SEWERS
And STREET SPECIFICATIONS

TABLE OF CONTENTS	2-8
<u>WATER MAINS</u>	<u>PAGE</u>
Section 1.00 – Scope	9
Section 2.00 – General Provisions	9
(A) Engineered Design	9
(B) Definitions and Abbreviations	9
(C) Authority of Inspector	10
(D) Contractor shall provide notice	10
(E) Traffic Control	11
(F) Rejected Materials	11
(G) Contractor’s Responsibility	11
(H) Safety Requirements	11
(I) As-Built Drawings	11
(J) City to Provide Utility Services	12
Section 3.00 – Protection of Existing Facilities	12
(A) General	12
(B) Responsibility for Repair	12
Section 4.00 – Trench Excavation	12
(A) General	12
(B) Topsoil	12
(C) Trenching	12
(D) Overexcavation	13
(E) Pavement Cuts	13
(F) Removal of Water	14
Section 5.00 – Bedding Materials	14
(A) Concrete Encasement	14
(B) Sewer Pipeline and Water Main Bedding	14
(C) Placement & Compaction of Bedding for Pipelines	14
(D) Stabilizing Material for Unstable Trenches	14
(E) Support for Manholes in Unstable Ground	15

WATER MAINS (contin.)

Section 6.00 – Placement and Compaction of Backfill	15
(A) Trench Backfill in Unpaved Areas	15
(B) Trench Backfill Under Streets	15
(C) Lift Depths for Backfill	15
(D) Moisture Conditioning for Backfill Material	15
(E) Compaction Demonstration Option	16
(F) Compaction Testing	16
(G) Maintenance of Backfill	16
(H) Contractor’s Warranty against Trench Settlement	16
Section 7.00 – Surface Restoration	17
Section 8.00 – Water Distribution System Materials and Installation	17
(A) Scope	17
(B) Design Criteria	17
(C) Material Handling and Storage	19
(D) Pipe, Fittings and Joints	19
(E) Valves and Valve Boxes	20
(F) Fire Hydrants	22
(G) Thrust Blocks	24
(H) Filling Water Mains	25
(I) Disinfecting Water Mains	26
(J) Hydrostatic Testing	26
Section 9.00 – Water Taps and Services	27
(A) Installation and Inspection	27
(B) Copper Service Lines	28
(C) Ductile Iron Service Lines	28
(D) Corporation Stops	28
(E) Tapping Saddles	28
(F) Curb Stops	28
(G) Curb Boxes	28
(H) Meter Pits	28
(I) Maintenance of Backfill & Compaction	29
(J) Disconnection of Existing Water Taps	29
Section 10.00 – Acceptance of New Pipelines	29
(A) Authorization to Place in Service	29
(B) Contractor’s Warranty	29

WATER MAINS (Contin.)

(C) Final Inspection	29
(D) Acceptance by the City	29
(E) Warranty Continues Until Notice of Acceptance	29
(F) Remedy for Failure to Honor Warranty	30
(G) Automatic Acceptance by the City	30
Section 11.00 – Modification of this Specification	30
(A) Changes	30
(B) Prohibition against Retroactive Application	30

SANITARY SEWERS

Section 1.00 – Scope	31
Section 2.00 – Design Criteria	31
(A) Pipe Line Materials	31
(B) Pipe Line Sizes	31
(C) Location, Cover, & Separation	32
(D) Alignment & Slope	32
Section 3.00 – Grade Stakes	33
Section 4.00 – Material Handling & Storage	33
Section 5.00 – Waterline Protection	33
(A) Vertical Clearance Below Water Lines	33
(B) Vertical Clearance Above Water Lines	33
(C) Water Line Protection Options	33
(D) Service Line Protection	33
Section 6.00 – Concrete Encasements	33
(A) Materials	33
(B) Installation	34
(C) Engineering Observation	34
Section 7.00 – Pipe, Fittings, and Joints	34
(A) Materials	34
(B) Rigid Poly Vinyl Chloride Pipe	34
Section 8.00 - Installation	34
Section 9.00 - Ditch Crossing	35
Section 10.00 - Sewer Pipeline Acceptance Criteria	36
(A) Alignment	36
(B) Minimum Grade	36

SANITARY SEWER (contin.)

(C) Infiltration	36
(D) Bedding, Backfill and Compaction	36
(E) Low Pressure Air Testing	36
(F) Vertical Pipe Deflection	37
(G) Video Inspection	37
(H) Patching	37
(I) Correction of Deficiencies	37
(J) Project Records	37
Section 11.00 – Sewer Taps and Services	38
(A) Contractor to Install Sewer Service Laterals	38
(B) Full Body Wye's	38
(C) Service Size & Slope	38
(D) Service Locations	38
(E) Service Locations to be Staked	38
(F) Service Locations to be Marked	38
(G) Existing Line Taps	38
(H) Disconnection of Existing Sewer Taps	38
Section 12.00 – Manholes	39
(A) General	39
(B) Barrel Size	39
(C) Precast Manholes	39
(D) Cast-in-place Manholes	39
(E) Manholes Steps	39
(F) Frames and Covers	39
(G) Manhole Sealant	39
(H) Construction	39
(I) Adjust Manhole Ring & Cover to Grade	39
(J) Seal Pipe Ends to Manhole	39
(K) Manhole Bases	40
(L) Continuous Pipe Through Manhole	40
(M) Connections to Existing Manholes	40
(N) Outside Drop Manholes	40
(O) Marking Completed Manholes	40

SANITARY SEWERS (contin.)

(P) Manhole Testing Requirements _____ 40

Section 13.00 – Acceptance of New Pipelines _____ 41

(A) Authorization to Place in Service _____ 41

(B) Contractor’s Warranty _____ 41

(C) Final Inspection _____ 41

(D) Acceptance by the City _____ 41

(E) Warranty Continues Until Notice of Acceptance _____ 41

(F) Remedy for Failure to Honor Warranty _____ 41

(G) Automatic Acceptance by the City _____ 41

Section 14.00 – Modification of this Specification _____ 41

(A) Changes _____ 41

(B) Prohibition against Retroactive Application _____ 41

STREET DESIGN AND ACCESS CRITERIA

Section 1.00 – General _____ 42

(A) Introduction _____ 42

(B) Street Classification _____ 42

(C) Soils and Materials Testing _____ 42

(D) Design Speed _____ 43

(E) Right of Way _____ 43

(F) Patching _____ 43

Section 2.00 – Basic Design Parameters _____ 43

(A) Sight Distance _____ 43

(B) Horizontal Alignment _____ 43

(C) Vertical Alignment _____ 44

Section 3.00 – Cross Section Elements _____ 44

(A) Concrete Pans, Curbs and Gutters (concrete drainage) _____ 44

(B) Travel Lane Standards _____ 45

(C) Shoulder Standards _____ 45

(D) Minimum Culvert Diameters _____ 46

(E) Retaining Walls _____ 46

(F) Guardrail _____ 46

(G) Signs _____ 46

(H) Pavement Design _____ 46

Section 4.00 – Other Elements of Design _____ 47

STREET DESIGN AND ACCESS CRITERIA (Contin)

(A) Intersection_____	47
(B) Cul-de-sacs and Dead ends_____	47
(C) Parking Spaces_____	47
(D) Driveways (accesses)_____	48
(E) Pedestrian/Bicycle Facilities_____	48
(F) Temporary Unpaved Streets_____	49
(G) Erosion Control_____	49
(H) Other_____	49
Section 5.00 – Acceptance of New Streets_____	49
(A) Authorization to Place in Service_____	49
(B) Contractor’s Warranty_____	50
(C) Final Inspection_____	50
(D) Acceptance by the City_____	50
(E) Warranty Continues Until Notice of Acceptance_____	50
(F) Remedy for Failure to Honor Warranty_____	50
(G) Automatic Acceptance by the City_____	50
Section 6.00 – Modification of this Specification_____	50
(A) Changes_____	50
(B) Prohibition Against Retroactive Application_____	50

TABLES

Table 1_____	51
Table 2_____	52
Table 3_____	54

STREET AND CONCRETE CONSTRUCTION STANDARDS

Concrete

General Notes_____	GN - 01
Drive over Curb and Gutter_____	C - 01
30” Curb and Gutter_____	C - 02
18” Curb and Gutter_____	C – 02a
Typical Driveway Details_____	C - 03
Typical Valley Pan at Intersections_____	C - 04

Curb Ramps_____	C - 05
Detectable Warnings_____	C - 06
Vertical Curb, Gutter, Parkway and Sidewalk_____	C - 07

Street

Existing Street Improvements_____	ST - 01
New Street Construction - Typical_____	ST - 02
Typical Overlay Section_____	ST - 03
Typical Asphalt Patches_____	ST - 04
Concrete Collars Details_____	ST - 05

STREET AND CONCRETE CONSTRUCTION STANDARDS (contin.)

Storm Drain

Storm Drain Manhole_____	SD - 01
Typical Trench Drain_____	SD - 02
Storm Drain Curb Inlet_____	SD - 03
Valley Pan Inlet_____	SD - 04
Area Drain_____	SD - 05

WATER AND SEWER CONSTRUCTION STANDARDS

Water

Typical Meter Installation_____	W - 01
Standard Water Meter_____	W - 02
1 ½” and Larger Meter and Vault_____	W - 03
Fire Hydrant_____	W - 04
Flushing Hydrant_____	W - 05
Meter Pit_____	W - 06
Thrust Block Details_____	W - 07

Sanitary Sewer

Standard Manhole_____	SS - 01
Drop Manhole_____	SS - 02
Cast Iron Manhole Ring and Cover_____	SS - 03

Miscellaneous

Water and Sewer Line Crossings_____	WS - 01
Ditch Crossing_____	WS - 02

CITY OF SALIDA
WATER MAINS
DESIGN AND CONSTRUCTION

SECTION 1.00 - SCOPE

Water Mains and Sanitary Sewers and Streets in and for the City of Salida shall be designed and constructed in accordance with these Specifications.

SECTION 2.00 - GENERAL PROVISIONS

(A) **ENGINEERED DESIGN**

A Registered Professional Engineer licensed to practice in the State of Colorado shall design all water and sewer system extensions and any system modifications within the City of Salida.

(1) **PLAN SUBMISSION**

All water and sewer designs shall be submitted to the City on 24" x 36" sheets for review prior to construction.

(2) **CITY APPROVAL**

All water & sewer system designs must be approved by the City prior to commencement of construction. City approval will be given when, in the reviewer's opinion, the proposed plans conform to the City specifications and otherwise meet the needs of the City.

(3) **AS-BUILT DRAWINGS**

When construction of new water & sewer systems has been completed to the satisfaction of the City, the Project Engineer shall submit As-Built Drawings of the project to the City.

(4) **CERTIFICATE OF COMPLETION**

Upon approval and acceptance of the As-Built Drawings by the City, a Certificate of Completion for the project will be issued. The system may then be placed in service.

(5) **NOTICE OF ACCEPTANCE**

Upon request by the Contractor after completion of the **one-year** warranty period, and after correction of any deficiencies, the City will issue a Notice of Acceptance, relieving the Contractor of any further responsibility for the work.

(B) DEFINITIONS AND ABBREVIATIONS

Wherever the following words, phrases or abbreviations appear in these specifications, they shall have the following meanings:

(1) **City** shall mean the body politic of the City of Salida, Colorado that may be represented by any applicable and appropriate representative or designee of the City Council, Administrative Staff, or Public Works Department.

(2) **City Code** shall mean all Building Codes, Zoning Regulations, Street & Utility Specifications, and Subdivision Regulations adopted by the City of Salida, Colorado.

(3) **Developer** shall mean any person or firm undertaking to improve and/or subdivide property, providing streets and utilities intended for inclusion in, and dedication to, the City of Salida.

(4) **Contractor** shall mean the person or firm actually building streets and utilities, either directly for the City, or for a private Developer.

(5) Project Engineer shall mean the professionally licensed person or firm designing streets & utilities for inclusion in, and dedication to, the City of Salida.

(6) Engineer or City Engineer shall mean the City's designated Engineering consultant, or his authorized representative.

(7) Public Works shall mean the Public Works Director, or his authorized representative, City of Salida, Colorado.

(8) Inspector shall mean an authorized representative of the City Public Works Department acting on behalf of the Public Works Director and/or the City's designated Engineering consultant.

(9) Specifications shall mean these Standard Specifications for Water Mains and Sanitary Sewers, all national standard specifications to which the City may refer, and such additional specifications that a private engineer may draft as part of plans prepared for any specific project.

(10) "Approved", as used in these specifications, shall mean that the City has not taken exception to plans, work, or methods in question. "Approval" by the City does not in any way relieve any Developer, Contractor, or Project Engineer of full responsibility for designing and executing all work in full accordance with the City Specifications.

(11) Wherever the words, "as directed", "as required", "as permitted", or words of like meaning are used, it shall be understood that the direction, requirements or permission of the City is intended. Similarly, the words "approved", "acceptable", "satisfactory" shall refer to approval by the City.

(12) Whenever references are made to standard specifications, methods of testing materials, codes, practices and requirements, it shall be understood that the latest revision of said references shall govern unless a specific revision is stated. Wherever any of the following abbreviations appear, they shall have the following meaning:

AASHTO - American Association of State Highway & Transportation Officials

ANSI - American National Standards Institute

ASTM - American Society for Testing and Materials

AWWA - American Water Works Association

APWA - American Public Works Association

CDOT - Colorado Department of Transportation

NSF - National Sanitary Foundation

(C) AUTHORITY OF THE INSPECTOR

Inspectors are assigned to assist the City in ensuring that work intended for dedication to the City is accomplished in accordance with the plans and specifications.

Inspectors shall serve as representatives of the City, and shall have such authority and responsibility as the City shall delegate to them, and shall make such decisions, and take such actions, as are consistent with the City's instructions to the Inspectors.

When inspectors are required to work overtime to accommodate the Contractor's work schedule, the Contractor shall reimburse the City for the added expense.

(D) CONTRACTOR SHALL PROVIDE NOTICE

The Contractor shall notify Public Works at least twenty-four (24) hours before beginning any water main or sewer main construction. If for any reason work should stop on a project during any stage of construction for a period of more than twenty-four (24) hours, it shall be the responsibility of the Contractor to notify Public Works at least twenty-four (24) hours prior to any resumption of work on the project. If the Contractor intends to work extended shifts, double shifts, or hours other than the normal workday of City personnel, he shall notify Public Works at least twenty-four (24) hours prior to such extension, except in the event of an

emergency. Failure to provide notification may provide sufficient cause for Public Works to order suspension of work on the Project.

(1) OPPORTUNITY TO OBSERVE THE WORK

Developers and Contractors shall provide Public Works with sufficient notice and opportunity to observe all work prior to backfilling or covering the work. Should any work be covered, buried, or closed up before Public Works has been accorded the opportunity to observe the work, Public Works shall have full authority to require the work be uncovered for observation and inspection, without expense to the City. The City will not accept any work, which has been buried without providing Public Works reasonable opportunity to observe the work, nor will the City release any payment therefore.

If Public Works does not observe the work in a timely fashion after being given sufficient notice (nominally 24 hours in advance unless special circumstances exist or Public Works requests more time), the Contractor may proceed with the work as though Public Works had observed it.

(2) CITY'S RIGHT OF ENTRY

As a condition precedent for the acceptance of utility systems intended for inclusion in the City's system, the City's representatives shall have unabridged right of entry for the purposes of observing the work to all property upon which such work is being performed.

(E) TRAFFIC CONTROL

The Contractor shall be required to provide adequate construction signing, flagmen, barricades, warning lights, etc., to warn vehicular and pedestrian traffic of work in progress and divert traffic as may be required during the course of construction. All signing shall be subject to the approval of Public Works, and shall conform in general to the CDOT Manual of Uniform Traffic Control. When specifically authorized by Public Works, portions of the streets may be closed to traffic for construction. The Contractor shall make every effort to keep the time of closure of such streets to a minimum. It shall be the responsibility of the Contractor to notify the Fire and Police Departments, the ambulance service, and the School District's Transportation Service twenty-four (24) hours prior to the closure of any street.

(F) REJECTED MATERIALS

All materials installed shall be free of defects of manufacture. Any defective or damaged materials found in the construction or on the construction site shall be marked and removed from the site. In the event the Contractor fails to remove rejected materials from the construction site within a reasonable length of time, the City may arrange for such removal at the expense of the Contractor.

(G) CONTRACTOR'S RESPONSIBILITY

It shall be the responsibility of the Contractor to read and fully comply with all the provisions of these specifications and all laws, regulations, and safety standards that apply to the work.

(1) Insurance Requirement

All contractors working within the City Right-of-Way shall provide proof of liability insurance in the amount of one million dollars and name the City of Salida as additionally insured.

(H) SAFETY REQUIREMENTS

All water main and sanitary sewer main installations in the City of Salida will be constructed in accordance with current OSHA safety regulations. It shall be the responsibility of the Contractor to fully comply with all safety regulations, including specifically the responsibility to provide a competent person on site at all time to ensure the work is executed in a safe manner. Comments by the Public Works Director or his representatives about jobsite safety issues shall not in any way relieve the Contractor of full authority, control and responsibility for job safety.

(I) AS-BUILT DRAWINGS

Prior to issuance of the Certificate of Completion by the City of new water and sewer system extensions, the Developer or Contractor shall provide the City with two sets of "AS-BUILT" drawings, one on 24" x 36" sheets; the other in digital form. These drawings shall have been prepared and signed by the Project Engineer, and shall show in sufficient detail all actual "as constructed" station numbers, elevations, dimensions, offsets, and details needed to locate, maintain, and connect to the facilities. Manholes, valve boxes, buried tees, wyes, ells, and services shall be located by station number and offset from centerline.

Satisfactory "AS-BUILT" drawings must be delivered to Public Works before the City will (1) accept the work; (2) issue a Certificate of Completion, (3) release final payment for work performed for the City; (4) issue a Certificate of Occupancy; or (5) issue a lien release for property served by the work. Failure to submit AS-BUILT drawings acceptable to the City may result in termination of City water and sewer service.

(J) CITY TO PROVIDE UTILITY SERVICES

Water and/or sewer service by the City to any project or development will be provided only after Public Works has issued a Certificate of Completion. The certificate will be issued only after Public Works is satisfied that the water and sewer facilities have been constructed in accordance with the plans and specifications, and acceptable As-Built drawings have been received by the City.

SECTION 3.00 - PROTECTION OF EXISTING FACILITIES

(A) GENERAL

The Contractor shall request underground utility "locates" on the site from all utility companies, and shall make every effort to protect existing facilities. The Contractor shall notify all interested parties prior to commencement of work, and shall make every effort to minimize interruptions of service during construction. The Contractor shall be fully responsible for any damage to existing utilities or structures, public or private, resulting from his operations, and he shall save the City harmless from any liability or expense for injuries, damages, or repairs to such facilities.

(B) RESPONSIBILITY FOR REPAIR

Should any utility be damaged in the construction operations, the Contractor shall immediately notify the owner of such utility, and unless authorized by the owner of the utility, the Contractor shall not attempt to make repairs. If, during construction, it is determined that any utility (including sewers, water mains, gas mains, power, phone, cable TV, drainage structures, or any above ground utility facilities) must be relocated, the Contractor shall notify the utility owner well in advance so that arrangements with the City and / or owners of the affected utility can be completed without delay of the work.

SECTION 4.00 - TRENCH EXCAVATION

(A) GENERAL

The Contractor shall determine the methods, procedures, and equipment that shall be used to construct the project in a good, workman like manner, in compliance with these Specifications, and in full compliance with all local, state, and Federal regulations, especially the OSHA standards. In the event that the Contractor fails to meet the Specifications, or if his actions adversely affect public safety and convenience, or the City's best interests, the City may require the Contractor to change methods, procedures, or equipment to ensure public safety and convenience, or to protect the City's interests.

(B) TOPSOIL & SPOILS

Where necessary and appropriate, the City may require that topsoil be removed and stored separately for later use in restoring the disturbed areas. All excavated materials not suitable for backfill shall be removed from the site at the Contractor's expense.

(C) TRENCHING

(1) SAFETY DEVICES

All trenches in excess of five (5) feet shall have the appropriate trench shoring device or trench box.

(2) SIDEWALL SLOPING

In the event that sidewalls of the trench are sloped to meet safety requirements, the sloping shall terminate at a depth not less than one (1) foot above the top of the pipe barrel and from that point down the trench width shall be limited to pipe diameter plus 24.

(3) EXCAVATING THE TRENCH BOTTOM

The trench shall be excavated to true line and grade, and the bottom shall be shaped to provide uniform bearing and support for the entire length of pipe. Bell holes shall be provided at each joint so that the pipe will be uniformly supported on the barrel portion of the pipe.

(4) TRENCH WIDTH

Trenches shall be a minimum of 36 inches wide. For line sizes larger than 8 inch the trench minimum width shall be determined using the formula of pipe size plus 12 inches either side of pipe. Trenches at tap locations may be required to be wider as determined by Public Works personnel.

(D) OVEREXCAVATION

(1) GENERAL

When the excavation is in firm earth, care shall be taken to avoid excavation below the established grade plus the specified over dig to accommodate any required granular bedding. All over-excavation below the design depth, which is made without the written authorization of the City, shall be refilled and compacted with approved granular fill material, by and at the expense of the Contractor.

(2) GROUNDWATER, UNSUITABLE TRENCH BOTTOM

In case soft or otherwise unsuitable foundation material is encountered in the trench bottom, such soil shall be removed to a depth as directed by the City. It shall be replaced with City approved backfill material and compacted to provide a suitable foundation for the pipe. The cost of such excavation and backfill shall be borne by the Contractor unless otherwise specified in the Contract.

If groundwater enters the trench as it is being excavated, only enough trench shall be opened so as to permit the laying of one (1) joint of pipe.

(3) OVEREXCAVATING FOR ROCK

When rock or hard clay is encountered in the trench bottom, the trench shall be excavated six (6) inches deeper than the design elevation. The over excavated zone shall be backfilled with suitable material approved by Public Works, and compacted according to these specifications. The cost of such excavation and backfill shall be borne by the Contractor unless otherwise specified in the Contract.

(4) RESPONSIBILITY FOR COSTS

It shall be the responsibility of the Contractor to fully evaluate the work and all surface and subsurface conditions prior to submitting a bid. The Contractor shall make such investigations, and shall perform such tests, as he deems necessary to fully evaluate on site conditions prior to submitting a bid and entering into a Contract to perform the work. All costs associated with subsurface conditions, which reasonably could or should have been ascertained by an experienced contractor, including, but not limited to, groundwater, unstable trenches, or rock, shall be the responsibility of the Contractor unless otherwise specified in the Contract.

(5) PAYMENT FOR EXTRA WORK

In the event that actual conditions encountered in the field differ materially from representations made in the plans, the specifications, or the geotechnical report for the project, the City may request a change in the Plans to address such conditions.

If the potential exists for the Contractor to incur additional expense due to changes made to the Plans requested by the City, the Contractor may submit a request for additional payment in accordance with the Change Order provisions of the Contract.

All costs of any work undertaken prior to issuance of a written Change Order authorized by the City shall be borne by the Contractor.

For public work administered by the City, the City shall bear the cost of extra work for which a written Change Order has been issued. For private work by a Developer constructing facilities intended for dedication to the City, the cost of extra work shall be borne by the Developer and / or the Contractor, in accordance with the terms of the Contract between those parties.

(E) PAVEMENT CUTS

Where excavation is required under paved areas, the pavement cut shall be a smooth, straight, vertical cut edge twelve (12) inches minimum beyond the trench wall, in accordance with the City's standard detail. On all cuts within the City ROW the pavement shall be cut by either saw or wheel. The Contractor shall replace the pavement with equal or better construction in accordance with standard City Details.

(F) REMOVAL OF WATER

The Contractor shall provide and maintain at all times ample means and devices to promptly and properly dispose of all water entering the trench excavation. All Contractor dewatering operations shall be conducted in accordance with a construction water discharge plan and permit in compliance with Colorado Water Quality Control regulations. Water shall be disposed of in a suitable manner without damage to adjacent property or without being a menace to public health and convenience. Trench water shall not be allowed to enter any pipelines either by gravity or by pumping. All open ends of the pipe shall be tightly plugged at the end of each day's work to insure that no water can flow into the sewer line. All manholes under construction shall be sealed tightly to prevent flows from entering the system.

SECTION 5.00 - BEDDING MATERIALS

Pipelines installed in the City of Salida shall be bedded in accordance with these alternatives, as decided by the City:

(A) CONCRETE ENCASEMENT

Concrete encasements may be used around sewer pipelines when the minimum vertical and horizontal separations between water and sewer lines cannot be achieved.

(See Sections 8(B)(5), 10(E) and 10(F) for water line protection details.)

When concrete encasements are required, the sewer pipe shall be set upon, and be fully covered with 4000 -psi concrete as shown on the plans or as required by the City. The minimum thickness of concrete around the pipe shall be one quarter (1/4) of the outside pipe diameter but not less than six (6) inches. Concrete encasements shall be reinforced with at least 4 each #4 rebar at the quarter points, or as directed by the City.

(B) SEWER PIPELINE AND WATER MAIN BEDDING

All sewer mains shall be bedded upon, and covered with, CDOT Class 6 road base or an approved alternative, such as crushed rock. All water mains shall be bedded upon, and covered with, CDOT Class 6 road base or an approved 3/4" minus material. The trench shall be excavated to a depth of six (6) inches below the established grade. Bedding material shall be placed under, around, and over the pipe to a minimum of twelve (12) inches above the pipe. The bedding material shall be compacted using vibratory equipment to 95% of maximum dry density as determined by ASTM D1557, Standard Proctor.

(C) PLACEMENT & COMPACTION OF BEDDING FOR PIPELINES

All pipes shall be thoroughly supported by bedding prior to placement of backfill. Bedding material shall be carefully worked under the haunches of the pipe and compacted in conformance with Section 5(B) prior to placement of primary backfill.

(D) STABILIZING MATERIAL FOR UNSTABLE TRENCHES

In the event unstable ground conditions are encountered in pipeline excavations, the trench shall be over-excavated to such additional depth as directed by the City, and backfilled to pipeline grade with 1-1/2" clean crushed rock to stabilize the trench bottom. See Section 4(D).

(E) SUPPORT FOR MANHOLES IN UNSTABLE GROUND

When unstable ground conditions exist at manhole locations, the Contractor shall over-excavate as directed by the City and construct a manhole foundation using 1-1/2" clean crushed rock to provide adequate support for the manhole.

SECTION 6.00 - PLACEMENT AND COMPACTION OF BACKFILL

(A) TRENCH BACKFILL IN UNPAVED AREAS

In general, backfill material for utilities installed in unpaved areas shall be the material which has been excavated from pipeline trenches on the site, provided it is free from objectionable materials, as determined by the City.

(1) ORDINARY BACKFILL MATERIAL

Ordinary backfill material shall generally consist of that material which has been excavated from the trench. Rubbish, frozen material, organic debris, broken concrete, broken pavement, other debris, stones or other consolidated material greater than two (2) inches in diameter when within twelve (12) inches of pipe, organic muck, or other materials considered deleterious by the City shall not be used for backfill. Clay and similar material with a plasticity index greater than twenty (20) will not be considered suitable for backfilling the trenches located in streets, roads, highway, or thoroughfares.

(2) IMPORTED FILL

Imported fill shall be used when, in the opinion of the City, the excavated material is not satisfactory for use as backfill, or whenever there is a shortage of satisfactory backfill material. The Contractor shall furnish all necessary suitable backfill material, and shall dispose of all condemned excavated material, at the Contractor's expense unless otherwise provided by the Contract. Imported fill shall be subject to approval by the City.

(3) BACKFILL METHODS

The trench shall be backfilled and compacted in shallow lifts using methods, equipment, and materials acceptable to the City, in such a manner as to avoid damage to, or displacement of, the installed main.

(4) COMPACTION OF ORDINARY BACKFILL

Backfill material in trenches in the right of way in unpaved areas, and in utility easements, shall be compacted to 90% of maximum density defined by ASTM D 1557, Standard Proctor, at +/- 2% of optimum moisture, using methods and equipment satisfactory to the City. Backfill material in the right of way of streets yet to be constructed shall meet the same requirements as (B) Trench Backfill Under Streets.

(5) DISPOSAL OF SPOILS

Unless otherwise specified, the Contractor at his expense shall remove all excess backfill material from the rights-of-way and public property.

(B) TRENCH BACKFILL UNDER STREETS

Trench Backfill under existing streets shall be CDOT Class 6 road base for the full depth of the trench, compacted using vibratory equipment to 95% of maximum dry density as determined by ASTM D1557, Standard Proctor.

(C) LIFT DEPTHS FOR BACKFILL

Backfill material shall be placed in eight-inch (8") lifts.

(D) MOISTURE CONDITIONING FOR BACKFILL MATERIAL

The moisture content of the backfill material shall be plus or minus 2% of optimum moisture, as determined by ASTM D 1557. The Contractor shall be prepared to moisten dry soils, or to dry excessively wet soils, as needed.

(E) COMPACTION DEMONSTRATION OPTION

If the Contractor proposes to use lift depths greater than City believes will allow full depth compaction to meet this specification, then the Contractor may, at his expense, demonstrate his proposed backfill methods, equipment, and lift depths on a trial section of trench. The Contractor shall engage an independent soil testing laboratory, at the Contractor's expense, to test the backfill at all depths. If the test results demonstrate that the Contractor can meet the specification to the satisfaction of the City, the City representative may, at his discretion, allow use of deeper backfill lifts in conjunction with the methods and equipment used in the Contractor's Demonstration Section.

(F) COMPACTION TESTING

Compacted backfill in trenches shall be tested for density at random depths and locations by an independent soils testing laboratory retained by the Contractor at his expense, at intervals and depths determined by or satisfactory to the City. The City may also conduct random density tests at the City's expense for purposes of confirmation. On City projects, the City will pay for all passing testing.

(1) PROCTOR VALUES

Maximum theoretical density (Proctor Value) shall be determined by an approved soil laboratory for each type of soil being used for backfill, and shall be re-checked at intervals determined by the City.

(2) REPORTING TEST RESULTS

All density test results shall be reported to the City and to the Contractor at the time of testing.

(3) READINESS FOR TESTING

The Contractor shall report to the City when the work has progressed to a point where it is ready to be tested. The Contractor shall provide the City with adequate advance notice (generally 24 hours) to allow scheduling of testing. The City shall decide whether to take tests at any given depth or section, and shall schedule testing so as to minimize interference with the Contractor's operations. The Contractor shall adjust his operations to allow access to the backfill for testing. Notwithstanding the Contractor's opinion of readiness for testing, if a lift of backfill is being placed, the previous lift shall be considered ready to test, and may be tested at the City's discretion.

(4) FAILING TESTS

Any backfill that fails to meet the density specification shall be reworked and retested until passing tests are obtained. Prior to acceptance of the work, for each failing test there shall be on record a passing retest taken at the same location and depth after the backfill has been reworked.

(5) COST OF RE-TESTING

The Contractor is responsible for the costs of retesting areas of backfill that failed to pass the initial and any subsequent testing.

(6) ACCEPTANCE OF THE WORK

All density tests must meet the specification prior to release of payment, acceptance of the work, or issuance of a Certificate of Completion.

(7) ASSIGNMENT OF RESPONSIBILITY FOR TESTING

The City representative may, at his option, assign responsibility for managing and reporting compaction testing to a Registered Engineer serving as Project Engineer, and may, at the City's option, rely upon the Project Engineer's certification that the work meets the specifications.

(G) MAINTENANCE OF BACKFILL

All backfill shall be maintained in a satisfactory condition, and all places showing signs of settlement shall be filled and maintained at the Contractor's expense throughout the warranty period.

(H) CONTRACTOR'S WARRANTY AGAINST TRENCH SETTLEMENT

The Contractor shall warrant all trench backfill against subsidence for a period of two years from the date of the Certificate of Completion. Any section of trench in existing paved street that settles more than 1.0" below the adjacent undisturbed pavement shall be repaired and resurfaced by the Contractor at his expense. All repairs shall be warranted by the Contractor for an additional year. The City representative may, at his discretion, hold appropriate retainage, or require the Contractor post a bond, for the warranty period.

All replacement materials and procedures shall be subject to inspection and approval by the City.

SECTION 7.00 - SURFACE RESTORATION

Where pavement, curb and gutter, sidewalks, drainage culverts, headwalls, ditches, lawns, fences, irrigation works, and other improvements have been removed during the course of the work, such items shall be restored to a condition equal to or better than original condition. In lieu of replacing landscaping, the Contractor may make private agreements with, and payments to, the affected landowners, and shall present signed releases from those landowners to the City prior to release of final payment.

The subgrade for all restored surfaces shall be compacted in accordance with this specification. All restoration of existing structures and conditions shall be made at the Contractor's expense.

Patching on streets in which a trench has been excavated shall consist of a 'T' patch. 'T' patch will be done so that after trench is filled and compacted a strip of asphalt twelve (12) inches wider than trench shall be cut out and replaced with new asphalt. Patch depth shall be the depth of existing asphalt but in no case less than 2 inches. On all cuts within the City ROW the pavement shall be cut by either saw or wheel.

SECTION 8.00 - WATER DISTRIBUTION SYSTEM MATERIALS AND INSTALLATION

(A) SCOPE

Water distribution systems in the City of Salida shall be designed and constructed in accordance with the standards of the American Water Works Association (AWWA), the Ductile Iron Pipe Research Association (DIPRA), the pipe manufacturer's recommendations, and with this specification.

American Water Works Association

6666 West Quincy Avenue

Denver, Colorado 80235

Handbook of Ductile Iron Pipe, Sixth Edition

Ductile Iron Pipe Research Association

245 Riverchase Parkway East

Birmingham, Alabama 35244

(B) DESIGN CRITERIA

PIPELINE MATERIALS

All water distribution mains shall be constructed of Ductile Iron Pipe, Class 50/PC350 or Class 52.

(1) Ductile Iron Pipe-Slip Joint

a. General

All distribution mains shall be Class 50/PC-350 Tyton Joint or class 52 ductile iron pipe. The pipe shall be designed in accordance with AWWA Standard C150/A21.50-96, "American Water Works Standard for the thickness design of ductile iron pipe," produced in accordance with AWWA Standard C151/A21.51-96, "American Water Works Standard for ductile iron pipe, centrifugally cast, for water or other liquids." And cement-mortar lined in accordance with AWWA Standard C104/A21.4-95, "American Water Works Standard for cement mortar lining for ductile iron pipe and fittings for water." The ductile iron exterior of the pipe shall be coated with standard bituminous coating approximately one (1) mil thick.

b. Size of Pipe

This specification shall cover ductile iron pipe in 4-inch, 6-inch, 8-inch, 12-inch, 16-inch, 20-inch, 24-inch, 30-inch, and 36-inch nominal diameters.

c. Joint Type

"Push-on single gasket" type conforming to applicable requirement of AWWA Standard C111, "Rubber-Gasketed joints for Ductile-Iron Pressure Pipe and Fittings."

d. Class and Type

Pipe furnished under this specification shall conform to the following pressure classes as shown in AWWA Standard C150, as a minimum:

Size- 4" thru 16" Pressure Class (psi) 350 or CL 50

Size- 20" Pressure Class (psi) 300

Size- 24" Pressure Class (psi) 250

Size- 30" and 36" Pressure Class (psi) 200

Higher-pressure class pipe will be required when the City of Salida determines that excessive dead load or other conditions warrant increased wall thickness.

e. Pipe Length

Pipe furnished under this specification shall have normal laying lengths of either 18 feet or 20 feet.

f. Material Strength

Iron used in the manufacture of pipe furnished under this specification shall be grade 60/42/10.

g. Cement Mortar Lining

Pipe furnished under this specification shall have standard thickness cement mortar linings in accordance with AWWA Standard C 104/A21.4 "Cement –Mortar Lining For Ductile Iron and Gray-Iron Pipe and Fittings for Water."

(2) PIPELINE SIZES

The City will designate connection points for new pipeline extensions, and will provide the project designer with information on existing pipe size and system pressure at those connection points. The Project Engineer shall size the water main extensions to provide adequate flow rates to properly serve the population of proposed development. New pipelines shall be no less than 8-inch diameter.

(3) OVERSIZE REQUIREMENTS FOR DISTRIBUTION

Larger pipe sizes will be specified by the City as needed to provide proper system wide distribution and fire flow capacity. The City will pay the difference in material costs only if sufficient time is given to appropriate the necessary budget. The developer shall be responsible to pay for any oversize in the event that enough time was not provided or in the event the city does not have the funding available.

(4) LOCATION AND COVER

Water mains shall generally be placed on street centerlines. Water mains shall be installed to maintain four feet (4') of cover from the top of the pipe to the final finished street grade.

(5) PROTECTION OF WATER MAINS FROM SEWERAGE LEAKS

Where sewer lines cross water mains, or come within ten (10) horizontal feet of each other, the sewer pipe shall be a minimum of eighteen (18) inches clear distance vertically below the water main. If

this clear distance is not feasible, the pipe section must be designed and constructed so as to protect the water main by encasing the sewer pipe. Encasement may be concrete (in accordance with Section 5(A)), or another, larger pipe that is continuous for at least 10' perpendicular distance on either side of the water main. See Sections 10(E) and 10(F) for details.

(6) LOOPING REQUIREMENT

Water main extensions shall be designed to make continuous loops, connecting to the City water system in at least two points wherever possible to provide alternate sources of supply.

(7) GRADE STAKES

The Developer's Engineer shall provide survey stakes defining alignment and depth for all water main installations. All fittings, valves, and accessories shall be staked for location. Hydrant locations and elevations shall be staked. Hydrants shall be set 2' behind the curb, within the parkway, and the flange at the base of the hydrant shall be set 1" to 3" above top back of walk.

(C) MATERIAL HANDLING AND STORAGE

Pipes, fittings, valves and accessories shall be loaded and unloaded or otherwise handled in such a manner as to minimize the possibility of damage prior to installation. All materials shall be stored at the construction site in such a way as to prevent damage and to assure they are kept clean.

(D) PIPE, FITTINGS, AND JOINTS

MATERIALS/ Fittings for Pipeline

(1) Ductile and Gray Iron Waterworks Fittings

a. General

All ductile and gray iron fittings shall be manufactured in accordance with the following AWWA Standards: C-104, "Cement-Mortar Lining for Cast-Iron and Ductile-Iron Fittings for Water," C-110, "Gray-Iron and Ductile-Iron Fittings, 3-inch Through 48-inch For Water and Other Liquids," C-153, "Ductile-Iron Compact Fittings 3-Inch Through 16-Inch for Water and Other Liquids," c-111, "Rubber-Gasketed Joints for Cast-Iron and Ductile-Iron Pressure Pipe and Fittings," with the following exceptions.

b. Cement Mortar Lining

All sizes of ductile and gray iron fittings shall be furnished with a cement-mortar lining of standard thickness as defined in referenced specifications and given a seal coat of bituminous material.

c. Type of Joint

All fittings shall be furnished with mechanical joint and/or plain ends conforming to referenced specification.

d. Pressure Class

All fittings shall be 250 PSI minimum pressure rating and shall conform to the dimensions and weights shown in the tables of referenced specifications.

e. All fittings shall be made from ductile or gray iron, which meets ASTM Grade, 60/42/10.

(2) INSTALLATION OF WATER DISTRIBUTION SYSTEMS

- (a) Protection of New Materials: All pipe and fittings shall be carefully lowered into the trench by means of a hoist, ropes or other suitable tools or equipment in such a manner as to prevent damage to the water main materials and protective coatings and linings. Under no circumstances shall water main materials be dropped or dumped into the trench. All pipe and fittings shall be carefully examined for cracks or other defects immediately before installation in final position.

- (b) Pipe Cleanliness: Foreign materials shall be prevented from entering the pipe. During pipe laying operations, no debris, tools, clothing or other materials shall be placed in the pipe. As each length of pipe is placed in the trench, the spigot end shall be centered in the bell and the pipe forced on and brought to correct line and grade. Precautions shall be taken to prevent dirt from entering the joint space.
- (c) Temporary Closures: At times when pipe laying is not in progress, the open ends of the pipe shall be closed by a watertight plug or other means approved by the City. If water is in the trench, the plug shall remain in place until the trench is pumped completely dry.
- (d) Install Pipe Uphill: Where pipe is laid on a grade of 10% or greater, the laying shall start at the bottom and shall proceed upward with the bell ends of the pipe upgrade.
- (e) Cut Pipe Ends Cleanly: When pipe is cut to insert valves or fittings, cuts shall be made in a neat and workmanlike manner without damage to the pipe, and shall provide a smooth end at right angles to the axis of the pipe.
- (f) Thrust/joint Restraints: All changes in direction in excess of ten (10) degrees shall be provided with mega lug joint restraints at the bend and also at one full pipe length after each end of bend or in some cases concrete thrust blocks will be required, appropriately sized by the Project Engineer based upon the bearing capacity of the soil on the site
- (g) Stable Trench Requirement: No pipe shall be installed when, in the opinion of the City representative, trench conditions are unsuitable.

(E) VALVES AND VALVE BOXES

(1) GENERAL

- (a) Valve Locations: The water distribution systems shall be designed so that only one block need be closed off in the event of a water line break. Valves on distribution lines shall be installed at each intersection, or at the discretion of the Public Works Director. Valves on transmission lines shall be installed at intervals determined by the City. Water line intersections shall be designed with a valve on each leg of the fitting to accommodate emergency shut-off. In business and high-density areas, sufficient valves shall be used to close off each block.
- (b) Valve Type: Gate Valves shall be installed on all water main pipes to 12". On Mains greater than 12" valve type will be as specified by the City.

(2) MATERIALS

(a) Waterworks Gate Valves– 2-Inch through 12-Inch

Gate valves shall conform to the specification for Waterworks Gate Valves described in this section. The valves shall be the same size as the main. Valves installed on potable water lines shall open to the left (counter clockwise).

General

All valves shall be manufactured in accordance with AWWA Standard C-500 "Metal-Seated Gate Valves For Water Supply Service" and AWWA Standard C-509 "Resilient-Seated Gate Valves For Water Supply Service, NPS For Water and Sewage Systems," with the following additional requirements or exceptions:

1. Valve Description

Valves shall be resilient seated gate (double disc if approved by the City of Salida), with cast iron or ductile iron body, fully bronze –mounted, with non-rising stem and parallel seats. All valves shall be epoxy coated internally and externally.

2. Service

All valves shall be suitable for frequent operation as well as service involving long periods of inactivity. The operating pressure for all sizes shall be 250 PSI with testing pressure of 500 PSI.

3. Valve Stems

Valve stems shall be threaded so that the valve can be opened by turning to the left (counter clockwise). The stem shall be non-rising and be sealed with "O" ring packing. All valves shall be equipped with a two-inch (2") square wrench nut.

4. Types of End Connections

All valves shall have a mechanical joint end with gasket gland and fasteners conforming to the ANS I_A21.11 (AWWA Standard C-111, "Rubber-Gasket Joints For Cast-Iron and Ductile Iron Pressure Pipe and Fittings").

5. Resilient Seat Type

Resilient seat type valves shall be acceptable for installation in the City of Salida water distribution system in sizes 2-inch through 12-inch.

Waterworks Butterfly Valves_16" and Larger

1. General

All valves shall be manufactured in accordance with AWWA Standard C504, "Rubber Seated Butterfly Valves," with the following additional requirements or exceptions:

2. Valve Description

Valves shall be of the tight closing, rubber-seat type, cast iron or ductile iron body. Valve discs shall rotate ninety (90) degrees from the full open position to the tight shut position and have a positive stop.

3. Service

All valves shall be suitable for applications involving throttling service and/or frequent operation as well as service involving long periods of inactivity. Valves shall be bubble-tight at rated pressures in either direction. The operating pressure for all sizes shall be 150 PSI or 250 PSI, with a testing pressure of 300 PSI or 500 PSI.

All valves shall be buried horizontal with the valve shaft horizontal and the operating nut shaft vertical.

4. Valve Operators

Valve operators shall be designed to hold the valve disc in any intermediate position between fully closed and fully opened without creeping or fluttering, and shall be threaded and geared so that the valve can be opened by turning to the left (counter clockwise). All valves shall be equipped with a two-inch (2") operating nut.

5. Types of End Connections

All valves shall have a mechanical joint end with gasket gland and fasteners conforming to the ANS I_A21.11 (AWWA Standard C-111, "Rubber-Gasket Joints For Cast-Iron and Ductile Iron Pressure Pipe and Fittings").

VALVE BOXES – 6" Shaft

1. General

All manufacturers shall be able to demonstrate that there is acceptable quality control program at the producing foundry and upon request shall furnish a quality control manual. All buried valves shall be provided with a six-inch (6") cast iron valve box, screw type. The valve box shall be of a design, which will not transmit shock or stress to the valve and shall have enough extension capability to be raised to final street grade. All valve boxes shall be rated for traffic service. Valve boxes shall conform to the specifications described in this section.

2. Materials

Castings shall be manufactured from iron conforming to the ASTM A536-84 grade 80-55-06 for ductile iron; Castings shall also meet Federal specification A-A60005 (formerly RR-F-621E).

3. Markings

Each casting shall be identifiable and show, the following optional markings, including but not limited to: name of producing foundry, country of manufacture, ASTM A48, CI 35B, cast or heat date; Additionally the individual part number, if part of the process. All castings shall be marked in accordance with all applicable laws and/or regulations.

4. Approved Manufacturer

Tyler- 6850/ 6855 Series Castings Inc. – 6850 / 6855 Series

(3) INSTALLATION

- (a) Valves shall be installed in accordance with AWWA specifications, at the locations shown on the drawings. Tees and mechanical joint valves shall be installed at all main line intersections. Valve interiors shall be cleaned of all foreign matter before installation. Valves shall be inspected in the open and closed positions to insure that all parts are in working condition.
- (b) Valve Boxes shall be installed with all valves. Valves twelve (12) inches and larger shall be provided with a bonnet. Valve boxes will be centered and plumb over the wrench nut of the valve with the box cover flush with the level of the finished grade or such level as may be directed by the City. Valve boxes in streets shall have a concrete collar installed in accordance with Standard Drawing ST-05. Valves installed in any location other than in a street shall be marked with a 4 x 4 Redwood post set at least 30" in the ground, extending 4' above grade, with the top 12" with painted blue.

(F) FIRE HYDRANTS

(1) HYDRANT LOCATIONS

In Residential Areas, fire hydrants shall be installed a maximum of 500 linear feet apart, measured along the street, generally at each intersection, with a travel distance of no more than 250 lf from any point on the street to the nearest hydrant.

In Business, Commercial, Industrial, and High Density Residential Areas hydrants will be located in conformance with the Uniform Fire Protection Code.

Where practical, hydrants shall be set on the side of the street closest to an inbound fire truck.

Hydrant locations must be approved by the Public Works Director and by the Fire Chief.

The Project Engineer will stake the location and elevation for all hydrants. In general, hydrants will be set centered between the curb and the sidewalk, with the bottom of the hydrant base flange set 1" to 3" above top back of curb.

(2) HYDRANT MATERIALS

- (a) Fire Hydrants shall be Waterous Pacer W-67 with a Storz adapter on the 4-1/2" pumper nozzle. Inlet sizes will be a minimum of six inches with a six-inch valve. At the City's discretion, hydrants with an eight-inch inlet and valve may be required. Each eight inch hydrant shall provide two 4 ½ inch nozzles with Storz adapters. The entire portion of the hydrant located above ground shall be bright red and shall be equipped with a National Standard pentagon operating nut opening counter-clockwise. Hydrant barrels shall be 5' from flange to top of inlet pipe.

(a) Dry-Barrel Fire Hydrants

1. General

All fire hydrants shall be designed and manufactured in strict compliance with AWWA Standard C502 "Dry-Barrel Fire Hydrants." All references made in this specification are to the above standard unless otherwise noted.

2. City of Salida Acceptable Brands and Service Limitations:

Waterous Pacer WB-67-250 Static Pressure to 250 PSI

3. Size of Hydrant

Hydrants shall have a main valve opening size of five and one-quarter (5 ¼) inches and shall be ordered for a five-foot (5') bury unless otherwise required and approved by the City of Salida.

Hydrant bury will be measured form the bottom of the hydrant lateral pipe to bury Line.

4. Type of Hydrant

All hydrants shall be the traffic model type. Hydrants shall be the three-way type with one (1) pumper nozzle and two (2) hose nozzles, all located on the same horizontal plane.

5. Inlet Connection

Hydrant base shall be provided with a mechanical joint inlet to accommodate 6-inch diameter ductile iron pipe, all in accordance with ANSI A21.11, (AWWA Standard C111, "Rubber Gasket Joints For Ductile Iron Pressure Pipe and Fittings").

6. Main Valve Assembly

Main valve of the hydrant shall be five and one-quarter (5 ¼") diameter compression type that closes with the water pressure. Gaskets for valves shall be a replaceable type fabricated of a resilient material, with a threaded bottom plate or nut, complete with seal to prevent leakage of the hydrant shaft.

The valve assembly shall include one or more drain valves that will work automatically with the main valve and drain the barrel when the main valve is in the closed position.

All parts of the main valve assembly shall be so designed that removal of the assembly form the barrel is accomplished without excavation.

7. Operating Shaft Nut

The operating nut shall be 1 ½" Pentagon shape. Bushings in the bonnet shall be so constructed that it will prevent the operating nut from traveling during opening or closing operation; also the bushing shall house a gasket or seal to prevent moisture or foreign material from entering the lubricant reservoir.

The hydrant shall open by turning the operating nut to the left in a counter clockwise direction and shall have an arrow on top of the bonnet to designate the direction of opening.

8. Pumper Nozzle and Cap

The pumper nozzle (*Storz Adapter*) shall be four and one-half (4-½) inch nominal diameter with National Standard Threads (NST). Threads shall be right-hand.

Nozzle caps shall be furnished with a synthetic rubber gasket installed in a retaining groove and the dimensions and shape of the nozzle cap nut shall be the same as the operating shaft nut.

Nozzle caps shall be furnished with security chains with one end of each securely attached to the upper barrel section of the hydrant.

All nozzle caps shall be removed by turning counter clockwise.

9. Hose Nozzle and Cap

The hose nozzle shall be two and one-half (2-½) inch nominal diameter with National Standard Threads (NST). Threads shall be right-hand.

Nozzle caps shall be furnished with a synthetic rubber gasket installed in a retaining groove and the dimensions and shape of the nozzle cap nut shall be the same as the operating shaft nut.

Nozzle caps shall be furnished with security chains with one end of each securely attached to the upper barrel section of the hydrant.

All nozzle caps shall be removed by turning counter clockwise.

10. Color

The entire portion of the hydrant located above ground shall be bright red.

(b) Auxiliary Valve: An appropriately sized Class 2500 auxiliary valve and valve box shall be installed for each hydrant on the tee at the main.

(c) Hydrant Drainage shall be provided by a drainage pit of 1-1/2" washed rock, a minimum of eighteen (18) inches below the hydrant to at least six (6) inches above the water drain openings (weep holes) in the hydrant and to a distance of one (1) foot around the elbow. All loose dirt shall be removed from the excavation prior to placement of the drainage rock. Plastic sheeting shall be placed over drainage rock before backfill to protect the drainage sump from dirt infiltration.

(G) THRUST BLOCKS

All fittings causing a change in the direction or velocity of flow in the pipe shall be provided with thrust restraints. Thrust restraints are generally not required on in-line valves unless specifically designated by the City.

(1) MATERIALS

Concrete for thrust blocks shall have a minimum cement content of five (5) sacks per cubic yard and a maximum water content of five (5) gallons per sack of cement and shall have a minimum compressive strength of 4000 psi in twenty-eight (28) days.

(2) INSTALLATION

All plugs, tees, bends and hydrants or changes in direction of ten (10) or more degrees shall be provided with thrust blocks or acceptable joint restraints. The thrust block shall be placed between the solid ground of the trench wall and the fitting. The concrete shall be placed so that the pipe and fitting joints will be accessible for repair. Sufficient concrete formwork shall be constructed to ensure

that no concrete comes in contact with, nor interferes with, installation or removal of the bolts on the fitting. Plastic sheeting shall be placed between the fitting and concrete.

(3) SOIL BEARING AREA

The size of the bearing surface of the thrust block upon the soil shall be determined by the Project Engineer, and included on the plans. Bearing area shall be calculated based upon the measured bearing capacity of the soil on site, but shall not be less than 4 square feet. Refer to Thrust Block Chart in back of book drawing W-07.

(4) PRECAST THRUST BLOCKS

The Contractor may install appropriately sized pre-cast pads for thrust blocks, provided the area between the pad and the undisturbed earth is backfilled with crushed road base gravel compacted to at least 95% Modified Proctor density, or flowable fill.

(5) MECHANICAL RESTRAINTS

Mechanical joint restraints such as "Mega-Lugs" may be used on ductile iron pipe in lieu of thrust blocks.

Mechanical Joint Pipe Restraints – 4-inch up to 48-inch Diameter Ductile Iron Pipe.

1. General

All mechanical joint pipe restraints shall be incorporated in a follower gland and shall include a restraining mechanism which, when actuated, imparts multiple wedging action against the pipe, increasing its resistance as the pressure increases. Twist-off nuts sized same as tee-head bolts, shall be used to ensure proper actuating of restraining devices.

Mechanical joint restraints shall be used for restraining fittings, valves and hydrants to reduce the installation of concrete reverse anchors, thrust reaction blocks and/or tie rods will be required where indicated on plans and standard drawings.

2. Materials

Glands shall be manufactured of ductile iron conforming to ASTM A536-80, grade 60-42-10. Restraining devices shall be of ductile iron heat treated to a minimum hardness of 370 bhn. Dimensions of the gland shall be such that it can be used with the American National Standard for Rubber-Gasketed Joints for Ductile-Iron or Gray-Iron Threaded Flanges, and ANSI/AWWA C153/A21.53 – American National Standard for Ductile-Iron Compact Fittings, 3-Inch through 24-inch and 54-inch through 64-inch for Water Service, of latest revision.

3. Class

Mechanical joint restraint devices shall have the following minimum working pressures to be not less than piping working pressure ratings:

- a) Ductile Iron Pipe- 350 PSI with a minimum safety factor of 2:1, for 4" through 20" diameter.
- b) Ductile Iron Pipe- 250 PSI with a minimum safety factor of 2:1, for 24" and larger.

4. Approved Manufacturer

Ductile Iron MJ Restraint:

EBAA Iron, Inc. –Mega lug, Series 1100 (3"-48")

Uni-Flange Corp. –Series 1400 (3'-36")

Ford – Megalug, series 1100

(H) FILLING WATER MAINS

When installation has been completed, the main shall be slowly filled with water moving at a velocity of less than one (1) foot per second. This water shall remain in the pipe for at least twenty-four (24) hours to allow time for disinfection. All air shall be expelled by means of taps or Air Release Valves installed by the Contractor at points of highest elevation. Upon completion of testing, all vent taps shall be mechanically capped or plugged by the Contractor.

As the chlorinated water flows past tees and crosses, all valves and hydrants shall be operated so as to disinfect appurtenances.

(I) DISINFECTING WATER MAINS

(1) GENERAL

Newly constructed water mains shall be disinfected with calcium hypochlorite tablets in general conformance with AWWA Standard C-651, "Disinfecting Water Mains". All new development shall pay the expense for any and all tests associated with a new line.

(2) CALCIUM HYPOCHLORITE DISINFECTION TABLETS

Five (5) gram calcium hypochlorite tablets containing 65% available chlorine by weight shall be used to disinfect water lines. Use of chlorine in granular form is prohibited.

(3) PLACEMENT OF TABLETS

Tablets shall be placed in each section of pipe and also in each hydrant, hydrant branch, and other appurtenances. The tablets shall be attached by adhesive to the top of the main. If the tablets are fastened before the pipe section is placed in the trench, their position should be marked on the pipe to assure installation at the top of the circle.

The adhesive may be Permatex No. 1 or an alternative approved by the City. There shall be no adhesive on the tablet except on the broad side next to the surface to which the tablet is attached.

Valves shall be manipulated so that the strong chlorine solution in the line being treated will not flow back into the line supplying the water.

(4) FINAL FLUSHING

After the 24 hour minimum retention period, the heavily chlorinated water shall be flushed from the main until the chlorine concentration in the water leaving the main is no higher than that generally prevailing in the system, or less than one (1) mg/l. The City representative shall test the water for residual chlorine. Heavily chlorinated water may not be discharged into the City sewer system.

(J) HYDROSTATIC TESTING

Newly constructed water lines shall be hydrostatically tested prior to acceptance by the City.

(1) COMBINED PRESSURE AND LEAKAGE TESTS

Newly constructed water mains and services shall be tested for leakage and pressure retention in general conformance with the protocol established by the Ductile Iron Pipe Research Association Handbook of Ductile Iron Pipe, as summarized and amended here after. The test shall be observed by the City representative. When a segment of line has been successfully tested, the City's observer shall prepare a written record of the test for the project files.

(2) PREPARATION

The segment of pipeline to be tested shall be backfilled sufficiently to safely restrain all elements of the system. Elevation differential within the test segment shall not exceed 50 vertical feet, and valves shall be installed as needed to meet the 50 VF limitation. The pipeline shall be slowly filled with water to avoid displacing disinfecting tablets, and to avoid shock loadings to the system. All air shall be purged from the system by venting all services, hydrants, and high points in the pipe. Taps may be installed at high points to vent air. After venting & testing has been completed, the vent taps shall be sealed with caps or plugs prior to backfilling. Disinfection procedures shall be completed in accordance with 8.09, and the heavily chlorinated water shall be discharged from the system. Heavily

chlorinated water may not be discharged into the City sewer system. Valves shall be set to prevent backflow into portions of the system that are in service.

(3) PROCEDURE FOR COMBINED PRESSURE & LEAKAGE TESTS

A positive displacement pump shall be used to pressurize the test section of line, using potable water stored in a clean tank. The test assembly shall be equipped with appropriate fittings, valves, and a gauge, which can be read to the nearest 1 psi. The system shall be maintained at test pressure, +/- 5 psi, for the duration of the test interval, by pumping additional water into the system intermittently as needed. Between pump runs, the pump shall be isolated from the test segment by valve closures. The volume of make up water required to maintain test pressure shall be accurately measured.

(4) TEST PRESSURE The test pressure ductile iron pipe shall be at least 1.5 times the working pressure at the point of testing, and shall be not less than 1.25 times the working pressure at the highest point of the section being tested.

(5) TEST INTERVAL

The total time for the combined pressure and leakage tests for each section shall be a minimum of two (2) hours.

(6) CRITERIA FOR SUCCESSFUL HYDROSTATIC TEST

The City will accept new pipeline only after the Contractor has demonstrated that system leakage under test pressure is less than the limits shown in the following table:

ALLOWABLE LEAKAGE FOR DUCTILE IRON PIPE

Pipe Size	U.S. Gallons, Per Hour, Per 1000 lf Test Pressure			
	100 psi	150 psi	200 psi	250 psi
8"	0.60	0.74	0.85	0.95
10"	0.75	0.92	1.06	1.19
12"	0.90	1.10	1.28	1.42
16"	1.20	1.47	1.70	1.90

(For others sizes and pressures, consult the DIPRA Handbook.)

If the leakage exceeds these standards, the Contractor shall locate and repair the leak(s) at the Contractor's expense prior to acceptance of the pipeline by the City.

SECTION 9.00 - WATER TAPS AND SERVICES

(A) INSTALLATION AND INSPECTION

- (1) Before excavation begins all tap fees and street/alley/right-of-way cut permits must be paid. Failure to do so could result in fines and penalties.
- (2) All Contractors who excavate on City property or City rights-of-way must show proof of current \$1,000,000 liability insurance coverage when obtaining a street/alley/right-of-way cut permit.
- (3) Contractors are responsible for providing their own barricades, cones and signs for traffic control purposes.
- (4) All water main extensions must be brought to the furthest edge of the private property line.
- (5) It is state law that before you excavate, you must call the Utility Notification Center of Colorado (UNCC) at 800-922-1987.

- (6) On existing mains, the City Public Works Department will make all taps 1-inch and smaller. Taps larger than 1-inch shall be made by the Contractor. The City will not tap any Steel Lines.
- (7) Before backfilling any water service line or new main line within City right-of-way, the Public Works Department must be contacted for an inspection. This applies to both new installation and repairs. Failure to call for an inspection will result in re-excavating and re-backfilling the line at the Contractor's or property owner's expense, in order that the work can be properly inspected.
- (8) Public Works personnel will make water taps and inspections between the hours of 8:00AM and 3:00PM, Monday through Friday. No taps or inspections will be done after 3:00PM.
- (9) Public Works reserves the right to require a live or wet tap in areas where water disruption is not advisable. Contractors wishing to use a live or wet tap must make application in writing to the Public Works Department two weeks prior to the date of tap. Consult with Public Works for appropriate parts and materials required for making the wet tap.

(B) COPPER SERVICE LINES

Service lines up to and including 2-inch shall be type K copper (in conformance with ASTM Specification B-88-62). Joints in copper service lines shall not be permitted under streets, slabs or driveways. The City will allow no more than one service line to share a common trench. A minimum 10-foot separation is required between service lines.

(C) DUCTILE IRON SERVICE LINES

Service lines larger than 2-inch shall be ductile iron

(D) CORPORATION STOPS

Corporation stops shall be Ford or A.Y. McDonald AWWA/CC taper thread with pack joint adapters, and shall be direct tapped into the main (Ex.F-1000-Size or McDonald 4701-22).

(E) TAPPING SADDLES

Tapping saddles shall not be used unless directed in writing by Public Works. Tapping saddles shall be AWWA/CC taper thread to match corporation stop. Tapping saddles up to 2-inch shall be double-strap or double-band. All materials shall be brass or stainless steel, or a combination of both. Tapping saddles over 2-inch shall have a stainless steel body

(F) CURB STOPS

Curb stops shall be Ford or A.Y. McDonald Ball Valve with pack joint adapters (B-44-444 or 6100-22). Curb stops shall be placed at the back of curb to allow adequate room for placement of the meter pit. If there is no curb, placement of the curb box will be determined by Public Works.

(G) CURB BOXES

Curb boxes shall be Tyler, screw-type (94E) or equal. Curb boxes with lids shall be installed with all service hookups. All curb boxes will accommodate a minimum pipeline bury depth of 4 feet 6 inches unless otherwise approved in writing by the Public Works. A.Y. MacDonald 5700 series is also acceptable.

(H) METER PITS

- (1) Meter pits shall be installed between the back edge of the curb and the front edge of the sidewalk in the parkway utility easement. Where no curb, gutter and sidewalk exist, Public Works shall determine the location of the meter pits.
- (2) Meter pits shall be as manufactured by Mid States Plastics, Inc., or DFW, tapered type of a modified polyethylene material, 36 inches in height.
- (3) Pit minimum diameter shall be as follows:

<u>Service Line Diameter (in)</u>	<u>Meter Pit Diameter (in)</u>
¾ - 1	24 tapered to 20

1 ½ and larger

Consult with Public Works

- (4) All meter pits shall be furnished with an aluminum dome with a cast iron outer lid and aluminum inner frost-proof lid (Castings M-70-AL). The cast iron outer lid shall be pre-drilled with a 2-inch hole for Radio-Read Meter Sensor. Lids can be standard or flush mount.
- (5) All water meters shall be Badger Meter Orion AMR Drive-by system
- (6) All meter yokes shall be Ford Series 80 with a dual check valve with pack joints (Ex.VHC82-44-33). For meters larger than one inch, all setters or piping shall have a dual check backflow prevention device installed.
- (7) All meter pits shall be equipped with a 48-inch length of R-11 fiberglass batt insulation sealed in a heavy duty plastic bag and draped over the meter and yoke. A second piece of insulation, similarly bagged, shall be placed between the inner and outer lids.
- (8) Alternate meter pits may be allowed with written approval by the Public Works Director. Current alternate meter pits are thermo-coil type meter pits as produced by Mueller and A.Y. McDonald. Developers wishing to use these type meter pits shall request application to the Public Works Department.

(I) MAINTENANCE OF BACKFILL & COMPACTION

The Contractor shall be responsible for backfill, compaction and maintenance of the water service line trenches for a period of one (1) year from the date of the Certificate of Completion, in accordance with Section 6(G).

(J) DISCONNECTION OF EXISTING WATER TAPS

The disconnection of a water service line shall be the responsibility of the property owner. The owner or contractor shall disconnect water at the water main by removing corporation stop and installing a threaded plug. Work must be inspected by the City Inspector.

SECTION 10.00 - ACCEPTANCE OF NEW PIPELINES

(A) AUTHORIZATION TO PLACE IN SERVICE

Newly installed pipelines may be placed in service upon completion of the installation, testing, and inspection outlined previously in this specification, receipt and acceptance of the As-Built Drawings by the City, and upon issuance of the Certificate of Completion by the City.

(B) CONTRACTOR'S WARRANTY

The Contractor shall warrant his work to be free from defects in materials and workmanship for a period of not less than one (1) year (the Acceptance Period). The Contractor may request release from Warranty responsibility one year after the date of signature on the Certificate of Completion.

(C) FINAL INSPECTION

At the end of the one (1) year Acceptance Period, and upon request by the Contractor, the City and the Contractor shall jointly observe the work. The City may make such tests and inspections as he deems necessary, consistent with these specifications. Any defects in the system resulting from defective materials, poor workmanship or any other cause attributable to the Contractor's work shall be corrected by the Contractor, to the satisfaction of the City, at the Contractor's expense.

(D) ACCEPTANCE BY THE CITY

After the Final Inspection, and upon satisfactory correction of any deficiencies by the Contractor, the City shall issue written "NOTICE OF ACCEPTANCE". At that point the City assumes responsibility for that pipeline, and the Contractor shall be relieved of further responsibility for the work.

(E) WARRANTY CONTINUES UNTIL NOTICE OF ACCEPTANCE:

Responsibility to initiate the Final Inspection procedure resides with Contractor. In the event that the Contractor fails to request a Final Inspection, the Contractor's Warranty shall continue to run until such a time as the work is inspected by the City, and a NOTICE OF ACCEPTANCE is issued by the City, or as terminated in 13(G).

(F) REMEDY FOR FAILURE TO HONOR WARRANTY:

Should a Contractor fail to honor his warranty obligations by refusing or neglecting to repair defective work during the one year warranty period, said Contractor shall forfeit eligibility to bid upon City work for a period of three (3) years. The City representative may, at his discretion, refuse to accept for inclusion into the City utility system any private work constructed by that Contractor during that period.

(G) AUTOMATIC ACCEPTANCE BY THE CITY:

Absent action by the Contractor requesting a Final Inspection, or by the City requesting Warranty work, use of the system by the City for a period of three (3) years from the date of the Certificate of Completion shall be considered de facto evidence that the system was satisfactorily constructed. In the absence of known defects requiring remedial work, the Contractor's warranty responsibility for the work shall automatically terminate three (3) years from the date of the Certificate of Completion.

SECTION 11.00 - MODIFICATION OF THIS SPECIFICATION

(A) CHANGES

The City of Salida may edit, amend, improve, or change these Specifications from time to time, as the Public Works Director shall deem necessary and in the best interests of the City. Plans submitted for review subsequent to the effective date of any revisions shall conform to the revised specification.

(B) PROHIBITION AGAINST RETROACTIVE APPLICATION

Changes to the Specifications shall not be applied retroactively to plans already approved for construction.

SANITARY SEWERS
DESIGN AND CONSTRUCTION

SECTION 1.00 - SCOPE

Sewage collections systems in or for the City of Salida shall be designed and constructed in accordance with the standards promulgated by the Water Quality Control Division of the Colorado Department of Public Health, by the Uni-Bell PVC Pipe Association, and by this specification.

Design Criteria Considered in the Review
of Wastewater Treatment Facilities

Policy 96-1

Colorado Department of Public Health & Environment

Water Quality Control Division

4300 Cherry Creek Drive South

Denver, Colorado 80222-1530

Handbook of PVC Pipe

Uni-Bell PVC Pipe Association

2655 Villa Creek Drive, Suite 155

Dallas, Texas 75234

SECTION 2.00 – DESIGN CRITERIA

(A) PIPELINE MATERIALS

All public sewerage collection pipelines shall be constructed of Polyvinyl Chloride (PVC) pipe manufactured in conformance with ASTM D-3034 (SDR 35), having a nominal inside diameter not less than 8".

(B) PIPELINE SIZES

Sewer collection pipelines shall be sized to carry the Design Flows based upon service area population estimates by the Project Engineer. Should the City conclude that a proposed new pipeline will ultimately serve a larger area and population than is included in an individual project, the City may direct the Project Engineer to design a larger pipeline. .

Multiple buildings within a single lot shall each require a singular water and sewer lateral connected to a mainline.

The Project Engineer shall design all sewer pipelines. In the absence of defensible design criteria to the contrary, the design shall be based upon the following sewage flow criteria:

(a) **Average flow** shall be determined by the following:

- (i) Residential - on a basis of 3.2 people per residence and 100 gallons per day per person
- (ii) Multi-family Areas - on a basis of 300 gallons per day per living unit.
- (iii) Commercial Areas - on a basis of 4600 gallons per day per acre or actual usage, whichever is greater.
- (iv) Industrial Areas - on a basis of 5040 gallons per day per acre or actual usage, whichever is greater.

- (b) **Peak Flow:** The average flow shall be multiplied by a peaking factor to obtain the peak design flow. The Project Engineer shall submit his peaking factor calculations and assumptions to the City with the plans.
- (c) **Infiltration** shall be estimated using the following two methods. The larger result obtained using these calculations shall be added to the peak flow to determine the design flow.
 - (i) A factor of 0.095 gallons per inch diameter per foot of pipe per day multiplied by the total length of pipe in feet and the diameter in inches.
 - (ii) 500 gallons per day per acre.
- (d) **Design Flow:** The sum of the peak flow and the infiltration allowance shall be used to calculate pipeline size.
- (e) **Calculations:** The Project Engineer shall provide the City with copies of his estimates and calculations.
- (f) **Grease Trap Requirements:** For all commercial developments concerning the selling of prepared food, the following shall determine the size of grease trap.

Deli – ice cream, no cooking	no trap needed	
Deli – cooking	in line trap	30 to 70 pound
Full service		
With ground		1000 gal box
Without ground		minimum 70 pound

Public Works will require maintenance records for all grease traps.

(C) LOCATION, COVER AND SEPARATION

Sewer mains shall generally be located under streets, south and west of street centerlines, or on centerlines of alleys. Sewer mains shall not be designed or installed in easements outside of public rights of way unless written permission is obtained from the City.

Sewer mains shall be located a minimum of ten (10) feet horizontally from existing or proposed water mains.

Manhole locations shall be shown on the plans by street station number and lateral offset from centerline.

Sewer mains shall be designed deep enough to serve basements and lower level bathroom facilities wherever possible. The Project Engineer shall endeavor to place all sewers 8' below finished street grade. At a minimum, all sewers shall be at least three and one-half (3 1/2) feet deep, measured from the top of the pipe to the proposed finish street grade. Where possible, sewers shall be installed deep enough to accommodate all future extensions and connections that can be foreseen.

(D) ALIGNMENT AND SLOPE

Sewer mains shall be designed such that the full flowing velocity is not less than two (2) feet per second, or greater than ten (10) feet per second. Generally, sewer mains shall be designed so that the pipeline between any two adjacent manholes is on a straight line.

MINIMUM SEWER SLOPE

<u>Sewer Size</u>	<u>Minimum Slope in Feet</u> <u>per 100 Feet</u>
8-inch	0.40
10-inch	0.28

12-inch	0.22
14-inch	0.17
15-inch	0.15
16-inch	0.14
18-inch	0.12
21-inch	0.10
24-inch	0.08
27-inch	0.067
30-inch	0.058
36-inch	0.046

SECTION 3.00 – GRADE STAKES

The Developer's Engineer shall provide grade stakes for all sewer main installation. These stakes shall locate the main both horizontally and vertically. All manholes shall be staked for centers, line, and elevation.

SECTION 4.00 – MATERIAL HANDLING AND STORAGE

All pipes, fittings, and accessories shall be loaded and unloaded or otherwise handled in such a manner as to minimize the possibility of damage prior to installation. All materials shall be stored at the construction site in such a way as to prevent damage and to assure they are kept as clean as possible prior to installation.

SECTION 5.00 – WATER LINE PROTECTION

(A) VERTICAL CLEARANCE BELOW WATER LINES

Where sewer lines cross water mains or come within ten (10) horizontal feet of each other, the sewer pipe shall be a minimum of eighteen (18) inches clear distance vertically below the water main. If this clear distance is not feasible, the sewer pipe section must be designed and constructed so as to protect the water main.

(B) VERTICAL CLEARANCE ABOVE WATER LINES

Should a situation exist where a sewer main must be constructed crossing above a water main, the minimum clear distance vertically shall be eighteen (18) inches, and the sewer pipe section shall be designed & constructed so as to protect the water main.

(C) WATER LINE PROTECTION OPTIONS:

- (a) The sewer pipe shall be encased in reinforced concrete at least 6" all around the pipe, for at least 10' horizontal perpendicular distance on either side of the water main, or;
- (b) The sewer pipe shall be sealed within another, larger continuous (joint free) pipe, for at least 10' horizontal perpendicular distance on either side of the water main. The sewer pipe shall be sealed within the encasement pipe with non-shrink concrete grout extending at least 6" into the larger pipe.

(D) SERVICE LINE PROTECTION

These requirements for water line protection from sewer lines shall be equally applicable to force mains and sewer service connections.

SECTION 6.00 – CONCRETE ENCASEMENTS

(A) MATERIALS

Concrete for sewer pipe encasements shall have a minimum cement content of five (5) sacks per cubic yard and a maximum water content of five (5) gallons per sack of cement and shall have a minimum compressive strength of 4000 psi in twenty-eight (28) days.

Minimum reinforcing for concrete encasements shall be 4 each #4 bars, continuous for the length of the casing.

(B) INSTALLATION

Prior to placing the concrete for cradles or encasements, temporary supports consisting of concrete blocks or bricks shall be used to support the pipe in place. Not more than two (2) supports shall be used for each pipe length, with one adjacent to the shoulder of the bell and the other near the spigot end.

(C) ENGINEERING OBSERVATION

No encasements shall be poured until the City has observed and approved the pipe to be encased and its supports.

SECTION 7.00 – PIPE, FITTINGS, AND JOINTS

(A) MATERIALS

All sewer pipe shall be rigid Polyvinyl Chloride (PVC).

(B) RIGID POLY VINYL CHLORIDE PIPE (PVC)

- (a) All PVC sewer pipe shall meet the requirements of ASTM Designation D3034 "Type PSM Poly Vinyl Chloride (PVC) Sewer Pipe and Fittings", latest revision. The maximum allowable length per section of pipe shall not exceed thirteen feet (13') for pipe diameters up to 10", nor twenty (20) feet for larger diameter pipe.
- (b) Wall Thickness - The wall thickness of all PVC pipe shall meet ASTM Designation D3034 SDR 35 or better.
- (c) Diameter - The diameter indicated on the drawings shall mean the inside diameter of the pipe. Pipe shall be so constructed that the initial vertical diameter does not decrease by more than 4% with a longer term maximum of 7 1/2%.
- (d) Joints - Pipe joint assemblies shall be bell and spigot with an O-ring rubber gasket, or solvent weld for clean-outs or lamp holes.
- (e) Marking - All PVC sewer pipe shall be marked with the following:
 - (i) Name or Trademark of Manufacturer
 - (ii) ASTM Specifications
 - (iii) Nominal Diameter
- (f) Acceptance - In addition to any deficiencies covered by ASTM D3034, PVC that has any of the following visual defects will not be accepted:
 - (i) Straightness: Any joint of pipe which has a camber (perpendicular offset from a straight line) of more than one half inch (1/2") in the length of the joint. Pipe with camber of less than 1/2" shall be installed with the curves laid horizontally alternating left and right.
 - (ii) Pipe which is sufficiently out-of-round to prohibit proper jointing.
 - (iii) Improperly formed bell and spigot ends.
 - (iv) Fractured, cracked, chipped, or otherwise damaged pipe.
 - (v) Pipe that has been damaged during shipment or handling.
- (g) Surface Finish - The interior and exterior surfaces of all PVC pipe shall be uniform in color, shall not have been "sunburned" during long term outside storage, and shall be smooth and free of scratches or blisters.

SECTION 8.00 – INSTALLATION

- (1) Before excavation begins all tap fees and street/alley/right-of-way cut permits must be paid. Failure to do so could result in fines and penalties.
- (2) All Contractors who excavate on City property or City rights-of-way must show proof of current \$1,000,000 liability insurance coverage when obtaining a street/alley/right-of-way cut permit.
- (3) Contractors are responsible for providing their own barricades, cones and signs for traffic control purposes.
- (4) All water main extensions must be brought to the furthest edge of the private property line.
- (5) It is state law that before you excavate, you must call the Utility Notification Center of Colorado (UNCC) at 800-922-1987.
- (6) Before backfilling any sewer service line or new main line within City right-of-way, the Public Works Department must be contacted for an inspection. This applies to both new installation and repairs. Failure to call for an inspection will result in re-excavating and re-backfilling the line at the Contractor's or property owner's expense, in order that the work can be properly inspected.
- (8) Public Works personnel will make sewer taps and inspections between the hours of 8:00AM and 3:00PM, Monday through Friday. No taps or inspections will be done after 3:00PM.
- (9) Pipe shall be installed at the depths, grades, and locations shown on the approved drawings. A pipeline laser shall be used to establish line and grade for the excavator and the pipe layers. Trained, qualified personnel using appropriate surveying equipment and methods shall set the laser to line and grade. The City may order cessation of work if the Contractor fails to provide trained and qualified personnel to set the laser.
- (10) The Project Engineer shall check actual flow line elevation at each manhole prior to installing pipe to the next manhole. The grade to the subsequent upstream manhole shall be adjusted by the Project Engineer to compensate for errors in the previous section.
 - If a pipeline installation error
 - (a) exceeds 0.5 vertical foot,
 - (b) causes encroachment upon the limiting minimum or maximum grades or depths, causes encroachment upon other utilities,
 - (c) interferes with water line clearances, or
 - (d) interferes with critical subsequent connections,
 then the section of pipeline containing the error shall be removed and correctly installed unless otherwise directed by the City.
- (11) Sewer pipelines shall be bedded in 3/4" road base or crushed rock as approved by the {Public Works Director. Sufficient handwork will be performed around the bell to ensure that the barrel of the pipe will have a firm bearing from end to end. The weight of the pipe and backfill shall be carried on the body of the pipe, and shall not be concentrated on the bell. All adjustments to line and grade must be made by scraping or filling under the body of the pipe. Wedging or blocking of the bell of the pipe will not be permitted.
- (12) The pipe shall be laid upgrade from structure to structure, with bell end upgrade, unless otherwise directed or permitted by the City.
- (13) The pipeline shall be backfilled & compacted in accordance with WATER MAIN; Section 6 of this specification.

SECTION 9.00 DITCH CROSSING

All ditch crossings specified on the plans shall be constructed in accordance with these specifications.

SECTION 10.00 SEWER PIPELINE ACCEPTANCE CRITERIA

Pipelines constructed for, or to be dedicated to, the City of Salida must meet the following minimum criteria before becoming eligible for acceptance into the City system.

(A) ALIGNMENT

The City shall determine allowable tolerances for misalignment based upon the size, slope, and anticipated flow volumes for the pipe, using the following criteria for guidance:

- (a) Through Visibility (Lamp Test): The Inspector must be able to see at least 2/3's of a full circle when looking through the pipeline from manhole to manhole. Sewer mains & manholes shall be clean and free of obstructions.
- (b) Vertical dips in the grade of the installed pipeline shall not be permitted.
- (c) Line & Grade in the installed pipeline at each manhole shall be within +/- 1' horizontally & +/- .5' vertically of the design, provided that any errors do not infringe upon critical subsequent connections, other utilities, easements, rights of way, curb, gutter, and pan flow lines, storm drainage facilities, water line clearances, minimum depths, or minimum grades.

(B) MINIMUM GRADE

All sections of the pipeline must have positive fall from manhole to manhole, and no more than 5% of the total length of the project may be installed at grades less than the minimums stated in Section 10(B)(4).

(C) INFILTRATION

The city will not approve any pipeline installation if there is any infiltration along any length of the pipeline. Approved testing method is pressure testing.

(D) BEDDING, BACKFILL, & COMPACTION

The pipeline shall have been bedded in accordance with Section 5 and backfilled & compacted in accordance with Section 6 of this specification. Sufficient density tests shall be made during the backfill process to demonstrate to the City that the compaction methods & equipment employed on the project were satisfactory for the conditions. All areas where the density tests failed to meet the specification shall be reworked until passing tests are obtained, in accordance with section 6(F). All test results shall be filed with the project records.

(E) LOW PRESSURE AIR TESTING:

All sections of sewer pipeline, including service laterals, shall be tested for integrity by low pressure air testing in accordance with the recommendations of the Handbook of PVC Pipe of the Unibell PVC Pipe Association. Any section that fails to hold pressure within .5 psi for the test interval, in accordance with the test protocol, shall be repaired at the Contractor's expense.

- (a) Backfill: The pipeline shall be backfilled sufficiently to restrain the pipe laterally & vertically.
- (b) Test Pressure: The sewer pipeline will be plugged at each pair of manholes, and pressurized with compressed air to 3.6 psi +/- .1 psi above groundwater pressure, if any.
- (c) Maximum Pressure Drop: Loss of air pressure during the test interval, defined below, shall not exceed .5 psi. The test interval shall be the sum of the test time for the main line plus test time for the service laterals, in accordance with the accompanying table:

MINIMUM TEST INTERVAL

(MINUTES)

SEWER MAIN AIR TEST FOR A 0.5 PSI MAXIMUM PRESSURE DROP

Pipe	Pipeline Length
------	-----------------

Diam.	100'	150'	200'	250'	300'	350'	400'	450'
4"	1:53	1:50	1:50	1:50	1:50	1:50	1:50	1:50
6"	2:50	2:50	2:50	2:50	2:50	2:50	2:51	3:12
8"	3:47	3:47	3:47	3:47	3:48	4:26	5:04	5:42
10"	4:43	4:43	4:43	4:57	5:56	6:55	7:54	8:54
12"	5:40	5:40	5:42	7:08	8:33	9:58	11:24	12:50
15"	7:05	7:05	8:54	11:00	13:21	15:35	17:48	20:02

(F) VERTICAL PIPE DEFLECTION

At any time prior to Final Acceptance of the project, the City representative, at his discretion, may measure any section of the sewer pipeline for vertical ring deflection. This is typically accomplished by pulling a mandrel through the pipeline. Maximum ring deflection of the pipeline under load shall be limited to 5% of the vertical internal pipe diameter. All pipe deflection exceeding 5% shall be repaired or replaced by the Contractor at no expense to the City.

(G) VIDEO INSPECTION

Prior to final acceptance the contractor shall submit to the City a copy of the video inspection of the sewer pipeline. The video inspection shall show footages and all taps and manholes. This video inspection shall become the property of the City of Salida and shall be used to determine condition of installation. Deficiencies discovered during the video inspection shall be the contractor's responsibility to correct.

(H) PATCHING

Patching on paved streets in which a trench has been excavated shall consist of a 'T' patch. 'T' patch will be done so that after trench is filled and compacted a strip of asphalt twelve (12) inches wider than trench shall be cut out and replaced with new asphalt. Patch depth shall be the depth of existing asphalt but in no case less than 2 inches. On all cuts within the City ROW the pavement shall be cut by either saw or wheel.

Patching on unpaved streets will consist of using native material up to one foot finished grade. Then Class 6 road base shall be used to finished grade. Entire work area shall be restored to the same or better condition than prior to excavation

(I) CORRECTION OF DEFICIENCIES

The Contractor shall correct, at his own expense, any deficiencies in alignment, grade, backfill, compaction, infiltration, air leakage, inverts, manholes, broken pipe, or surface restoration before the pipeline is placed in service, before release of progress payments for that portion of the line, and before issuance of the Certificate of Completion.

(J) PROJECT RECORDS:

When each segment of pipeline has been successfully inspected & tested, a written record of the lamp test, actual drop & grade between manholes, TV inspection (if any), infiltration (if any), compaction tests, and air test results shall be placed in the project files with the As-Built Drawings.

SECTION 11.00 - SEWER TAPS AND SERVICES

(A) SEWER SERVICE LATERALS

All sewer service laterals shall be installed by contractor. All connections to sewer mains shall be done by the Public Works Department. The exception is on new subdivisions, whereas the contractor shall make all connections prior to acceptance by the city. All connections shall be inspected by the Public Works Department.

(B) FULL BODY WYE'S

New sanitary sewer mains shall utilize full body wye fittings, so tap is to the top of pipe, with elastomeric gaskets installed in the main for service line connections.

(C) SERVICE SIZE & SLOPE

Service laterals for individual residences, and for multi-family residences of up to 4 units, shall be 4" PVC, ASTM D 3034 (SDR 35), installed on a grade of not less than 1%. Service laterals for multi-family residences of more than 4 units, and for commercial or industrial usage, will be individually sized by the Project Engineer. All service sizes larger than 4 inches shall be connected to the main by the installation of a manhole.

(D) SERVICE LOCATIONS

Service lines are to be installed at standardized locations throughout the subdivision, preferably near the center of the lot away from the power, phone, & TV utilities which tend to congregate at lot corners. Service lines shall be installed to a point inside the property line, and 2' beyond the dedicated easement, and shall be capped or plugged with a fitting suitable to withstand pressure testing.

(E) SERVICE LOCATIONS TO BE STAKED

The Project Engineer shall place a grade stake locating each sewer service before it is installed. Both the Wye and the end of the service shall be so staked. The actual installed location of service wye's, and the ends of the service laterals shall be measured and recorded by the Project Engineer on the As-Built Drawings, using street station numbers and perpendicular offset distances from centerline.

(F) SERVICE LOCATIONS TO BE MARKED

The end of the installed service line shall be marked with a 4" x 4" timber post or 4" PVC sewer pipe, painted green, extending from the bottom of the service line to a point approximately 18" above grade.

(G) EXISTING LINE TAPS

New taps to an existing sewer line shall be done with Fast Fit Sewer taps (3904tseff) with Epoxy kits (3904kit). Tap is to be made at top of pipe.

(H) DISCONNECTION OF EXISTING SEWER TAPS

Disconnection of sewer service lines shall be responsibility of the property owner. Disconnection shall take place within 2 feet of the main. The side closest to the main shall be capped and inspected prior to backfill by the City Inspector.

SECTION 12.00 - MANHOLES

(A) GENERAL

Manholes shall be installed at the end of each line; at all changes in grade, size, or alignment; at all pipe intersections; and at intervals of not more than 350 feet apart. All dead end manholes where future sewer main extension is anticipated shall have line laid through the manhole a maximum of one (1) pipe length with the size designated by the City, and shall be plugged with an approved plug provided by the Contractor.

(B) BARREL SIZE

The internal diameter of the manhole barrel shall not be less than forty-eight (48) inches for sewers of sizes eighteen (18) inch or less; sixty (60) inches for sizes twenty-one (21) to forty-eight (48) inch; seventy-two (72) inches for sizes larger than forty-eight (48) inch.

(C) PRECAST MANHOLES

Precast manhole barrels and cones shall be manufactured in conformity with ASTM C478, and shall be so marked by the manufacturer.

(D) CAST-IN-PLACE MANHOLES

Concrete used in cast-in-place manholes and manhole bases shall have a twenty eight (28) day strength of 4000 psi and shall contain not less than six (6) sacks of Portland Cement per cubic yard.

(E) MANHOLE STEPS

Manhole steps shall be either aluminum, plastic, or, and shall be cast into the manhole wall at the same time the manhole section is cast. The manhole steps shall be nine and one-quarter (9 1/4) inches wide by twelve and three-quarters (12 3/4) inches long. The top step shall be no more than twenty-four (24) inches from the top of the manhole. The bottom step shall be no more than eighteen (18) inches from the bench of the manhole. Steps shall be spaced no more than sixteen (16) inches apart.

(F) FRAMES AND COVERS

Manhole frames and covers shall be 400 pounds cast iron, twenty-four (24) inch I.D., Denver Heavy Pattern, as manufactured by MacClear Manufacturing Company of Denver, Colorado, Comco Foundry, Inc., Commerce City, Colorado, or approved equal. The cover shall fit the ring in accordance with the manufacturer's dimensions. Covers with more than one lifting hole will not be accepted. The lifting notch shall be on the covers edge and not in the center and shall not allow surface water to enter the manhole.

(G) MANHOLE SEALANT

All joints between manhole sections and pipe openings shall be sealed with an approved watertight sealant ("Rub-R-Nek", or equal). Manholes in areas with high water tables shall be coated on the exterior with an approved watertight sealant. Grade rings and cover rings shall be sealed to the top of the cone with "Rub-R-Nek".

(H) CONSTRUCTION

Manholes shall be installed or constructed at the locations and to the elevations indicated on the drawings. Manholes shall be backfilled using a class 6 road base or approved alternate.

The City's written approval shall be required prior to installation of any non-standard size, shape, or type manholes.

(I) ADJUST MANHOLE RING & COVER TO GRADE

The cone section shall not extend closer than eight (8) inches and not more than ten (10) inches from the top of the manhole cover. Precast concrete adjustment rings shall be used on top of the cone to support and adjust the manhole ring & cover to the required final grade.

(J) SEAL PIPE ENDS TO MANHOLE

Where the sewer main enters the manhole, appropriate measures shall be taken to prevent any infiltration of groundwater into the system.

(K) MANHOLE BASES

Manhole bases shall be constructed as shown on the Standard Manhole Detail drawing. Inverts shall be cast with uniform curves and smooth surfaces. The floor of the manhole outside of the channel shall be finished smooth surface and shall slope to the channel. The minimum thickness of the base shall not be less than eight (8) inches under the invert of the manhole channel.

(L) CONTINUOUS PIPE THROUGH MANHOLE

The sewer may be laid continuously through manhole locations wherever grade and alignment permit. After the invert has been cast, the upper half of the pipe shall be cut out and the bottom cleaned and finished. Precast inverts may be used when approved by the City.

(M) CONNECTIONS TO EXISTING MANHOLES

Sewer pipe connection to existing manholes where there is no existing pipe stubbed out shall be made in such a manner that the finished work will conform as nearly as practicable to the requirements specified for new manholes. The new sewer shall be designed and located so flowline will be as close to possible to the top of the existing pipe. The Contractor shall break out as small an opening in the existing manhole as practical to insert the new sewer pipe. The existing concrete foundation bench shall be chipped to fit the new pipe. Non-shrink cement grout shall be used as necessary to smoothly finish the new invert and to seal the new line so the junction is watertight. Flowlines shall be constructed in a professional manner, finished smooth, and shaped to provide directional control of the flow.

(N) OUTSIDE DROP MANHOLES

Whenever the elevation difference between the incoming sewer invert and the invert of the manhole cannot be accommodated to the City's satisfaction by a transition in the invert, an outside drop shall be constructed in accordance with the City Standard Detail SS-03.

(O) MARKING COMPLETED MANHOLES

Manholes installed outside of street rights of way shall be marked with a 4 x 4 inch timber set (4) feet above finished grade.

(P) MANHOLE TESTING REQUIREMENTS

Manholes shall be vacuum tested to ensure no infiltration. A copy of test showing results shall be submitted prior to acceptance.

SECTION 13.00 - ACCEPTANCE OF NEW PIPELINES

(A) AUTHORIZATION TO PLACE IN SERVICE

Newly installed pipelines may be placed in service upon completion of the installation, testing, and inspection outlined previously in this specification, receipt and acceptance of the As-Built Drawings by the City, and upon issuance of the Certificate of Completion by the City.

(B) CONTRACTOR'S WARRANTY

The Contractor shall warrant his work to be free from defects in materials and workmanship for a period of not less than one (1) year (the Acceptance Period). The Contractor may request release from Warranty responsibility one year after the date of signature on the Certificate of Completion.

(C) FINAL INSPECTION

At the end of the one (1) year Acceptance Period, and upon request by the Contractor, the City and the Contractor shall jointly observe the work. The City may make such tests and inspections as he deems necessary, consistent with these specifications. Any defects in the system resulting from defective materials, poor workmanship or any other cause attributable to the Contractor's work shall be corrected by the Contractor, to the satisfaction of the City, at the Contractor's expense.

(D) ACCEPTANCE BY THE CITY

After the Final Inspection, and upon satisfactory correction of any deficiencies by the Contractor, the City shall issue written "NOTICE OF ACCEPTANCE". At that point the City assumes responsibility for that pipeline, and the Contractor shall be relieved of further responsibility for the work.

(E) WARRANTY CONTINUES UNTIL NOTICE OF ACCEPTANCE:

Responsibility to initiate the Final Inspection procedure resides with Contractor. In the event that the Contractor fails to request a Final Inspection, the Contractor's Warranty shall continue to run until such a time as the work is inspected by the City, and a NOTICE OF ACCEPTANCE is issued by the City, or as terminated in 13(G).

(F) REMEDY FOR FAILURE TO HONOR WARRANTY:

Should a Contractor fail to honor his warranty obligations by refusing or neglecting to repair defective work during the one year warranty period, said Contractor shall forfeit eligibility to bid upon City work for a period of three (3) years. The City representative may, at his discretion, refuse to accept for inclusion into the City utility system any private work constructed by that Contractor during that period.

(G) AUTOMATIC ACCEPTANCE BY THE CITY:

Absent action by the Contractor requesting a Final Inspection, or by the City requesting Warranty work, use of the system by the City for a period of three (3) years from the date of the Certificate of Completion shall be considered de facto evidence that the system was satisfactorily constructed. In the absence of known defects requiring remedial work, the Contractor's warranty responsibility for the work shall automatically terminate three (3) years from the date of the Certificate of Completion.

SECTION 14.00 - MODIFICATION OF THIS SPECIFICATION

(A) CHANGES

The City of Salida may edit, amend, improve, or change these Specifications from time to time, as the Public Works Director shall deem necessary and in the best interests of the City. Plans submitted for review subsequent to the effective date of any revisions shall conform to the revised specification.

(B) PROHIBITION AGAINST RETROACTIVE APPLICATION

Changes to the Specifications shall not be applied retroactively to plans already approved for construction.

CITY OF SALIDA
MINIMUM STREET DESIGN AND ACCESS CRITERIA

SECTION 1.00 - GENERAL

(A) INTRODUCTION

The purpose of this document is to specify established standard principles and practices to be used in the design and construction of streets in order to provide for uniformity of streets within the City of Salida and to ensure the safety of the general public. Designs of streets for construction within the City of Salida shall be approved by the City prior to such construction. The design factors, formulas, and tables are intended to serve as guidelines for street design. All streets shall be designed by a Colorado Registered Professional Engineer.

Unless modified herein, all designs shall comply with the CDOT (Colorado Department of Transportation) *Design Guide*, latest edition. Other manuals recommended for reference include *A Policy on Geometric Design of Highways and Streets* and *Guidelines for Geometric Design of Very Low Volume Local Roads* (ADT < 400) both published by AASHTO (American Association of Street Highway and Transportation Officials). Another reference manual that may be used is "Residential Streets" Third Edition, Published jointly by ULI, NAHB, ASCE, and ITE. It is available through the Urban Land Institute. Deviation from the requirements of these criteria must be approved by the Public Works Director.

(B) STREET CLASSIFICATIONS

The following classifications shall be utilized in determining the criteria under which a street is to be designed.

1. ***Local Streets*** – Provide primary access to abutting properties.
 - a. Commercial
 - b. Residential
2. ***Collector Streets*** – Carry traffic from local streets to Arterial Streets, Highways and Principle generators within the community, such as neighboring shopping centers, schools and recreation areas.
3. ***Arterial Streets*** – Designed for the movement of through traffic and heavy local traffic. Arterials generally connect major traffic generators. In most instances, parking is not allowed on arterials. Having greater than 2000 vehicle trips per day.

(C) SOILS AND MATERIALS TESTING

All soils and material testing shall be done by a soil/material-testing firm under the supervision of a Colorado Registered Professional Engineer.

Improvements made within City ROW, soils testing and identification of the existing conditions shall be submitted to the City with recommendations for structural section. Structural sections shall designed in accordance to Section II, H

Improvements within City ROW shall be supervised by a soil/material-testing firm. The testing firm will be required to provide subgrade and road base for compaction test, materials testing of asphalt, road base, and concrete, and density tests of asphalt. All tests shall meet CDOT requirements. The City shall be notified of any failed tests or unsuitable soils on site. Reports shall be provided to the City.

If unsuitable soils are encountered, a modified design shall be submitted by the soils-testing firm to the City for approval.

The City may not accept projects or may require a longer warranty period if there are test failures or testing has not been completed according to the requirements of this section or recommendations by the soils-testing firm.

(D) DESIGN SPEED

The choice of design speed is influenced principally by the character of terrain, type of roadway and traffic volume.

Design speeds to be utilized for street design in the City of Salida are listed in Table 3.

(E) RIGHT OF WAY

The width of rights-of-way (ROW) required depends on the proposed or future street classification, topography in the area, and other physical controls. Minimum ROW widths are listed in Table 2.

Additional ROW width may be required to facilitate future widening and other improvements as traffic and development warrants or where it is necessary to meet side slope requirements.

(F) PATCHING

Patching on streets in which a trench has been excavated shall consist of a 'T' patch. 'T' patch will be done so that after trench is filled and compacted a strip of asphalt twelve (12) inches wider than trench shall be cut out and replaced with new asphalt. Patch depth shall be the depth of existing asphalt but in no case less than 2 inches. On all cuts within the City ROW the pavement shall be cut by either saw or wheel.

SECTION 2.00 - BASIC DESIGN PARAMETERS

Roadways shall be designed using the standards in the CDOT *Design Guide* unless otherwise modified herein. Items not covered in either source shall use *A policy on Geometric Design of Highways and Streets*.

(A) SIGHT DISTANCE

A primary consideration in the design of a street is to provide adequate sight distance for safe and efficient operation. There are two types of sight distance to be considered, that required for visibility at an intersection, and that required for stopping. AASHTO standards shall be met for these types of sight distance.

(B) HORIZONTAL ALIGNMENT

1. *Standard for Curvature*-Table 3 gives minimum centerline radii for curves. The table is based on design speed only. Increased radii may be required if minimum sight distances are not satisfied.
2. *Superelevation*-Refer to the CDOT Design Guide, latest edition. For low speed Local Streets superelevation is generally not used. Consult with the City if superelevation is not used,
3. *Small Deflection Angles*-For small deflection angles, curves should be of sufficient length to avoid the appearance of an angle in the road.
4. *Reversing Curves*-True reversing curves shall not be used in the City of Salida except as noted herein. In cases where curves in opposite directions must be used, a tangent between shall be used. A minimum 100-foot tangent shall be used if at all possible between reverse curves to facilitate steering and control. Lesser tangent lengths may be considered with deflection angle curves less than 10 degrees.
5. *Broken Back Curves*-Broken back curves consisting of two curves in the same direction joined by a tangent less than 50 feet shall not be used in the City of Salida, except on local streets with prior approval from the City Engineer.

6. *Coordination with Vertical Alignment*-To avoid the possibility of introducing serious traffic hazards, coordination is required between horizontal and vertical alignment. Particular care must be exercised to maintain proper sight distances at all times.
7. *Pavement Transition*-A pavement transition is the area of variable pavement width encountered when changing from one roadway width, or section, to another. All pavement transitions shall be based on the following formula:

$$L = WS^2 / 60$$

Where: L = length of transition or taper (in feet)

S = posted speed limit (in mph)

W = offset in feet

(C) VERTICAL ALIGNMENT

8. *Grade Line*-The grade line is a reference line by which the elevation of the pavement and other features of the roadway are established. The grade line shall coincide with the street centerline for all streets.
9. *Grade*-The minimum and maximum grades as measured at the centerline shall be 0.5% and 7%, respectively.

Excessive changes in grade which create a roller coaster effect shall not be permitted. Connections with existing streets shall be smooth transitions and existing grades shall be shown in the design for at 150 feet on all sides of a connection.
10. *Vertical Curves*-Properly designed vertical curves should provide adequate sight distance, safety, comfortable driving, good drainage, and pleasing appearance. Vertical curves in the City of Salida shall be parabolic curves.

SECTION 3.00 - CROSS SECTION ELEMENTS

(A) CONCRETE PANS, CURBS AND GUTTERS (CONCRETE DRAINAGE)

1. General

Minimum grade in all concrete drainage systems shall be 0.5% measured along flowline. Concrete drainage systems shall be used when justified by sound engineering reasons based on the following:
 - a. Where required for proper drainage.
 - b. Where needed for channelization, pavement edge delineation, control of access, pedestrian safety, or other means of improving traffic flow and safety.
2. Types

For specifications on types of concrete drainage systems available refer to these Standards and in some cases to CDOT Standard Plans—M & S Standards, latest edition. Refer to these types as specified in that publication on any plans submitted to the City.
3. Cross Pans
 - a. Cross pans for drainage, located at stop intersections, shall be a minimum of 6 foot at stop signs and 8 foot on through streets.
 - b. Cross pans are not allowed on Collector streets unless specifically approved by the Public Works Director.
 - c. Cross pans are not allowed on Arterial streets.

- d. Cross pan approaches shall be designed using the appropriate design speeds as given in these specifications.
- e. Crown transitions where approaching a cross pan or an intersecting street shall be at maximum of one percent change 25 feet.

4. Location

Where concrete drainage systems are used, street width requirements shall be measured from lip of concrete to lip of concrete. The Public Works Director shall be consulted on the type of concrete drainage to be used at any location in the City.

5. Concrete Class and Additives

Concrete used for concrete drainage and sidewalks shall meet the following minimum requirements.

- a. *MixDesign* – A mix design shall be submitted to the City for all concrete to be used within City ROW.
- b. *Strength* – *Minimum 4000 psi.*
- c. *Fibers* – “Fibermesh” fibers or approved substitute shall be added to the concrete for strength, at the rate of 1.5 pounds of fiber per cubic yard of concrete.

(B) TRAVEL LANE STANDARDS

1. Cross Slope

- a. Cross slope on all streets shall be a minimum of 2.0 percent measured from street centerline to edge of asphalt of concrete. In areas of minimum centerline grade, 3.0 percent shall be considered.
- b. Temporary unpaved streets shall be crowned to 3.0 percent.
- c. When existing streets are overlaid, the maximum cross slope shall not exceed 4.0 percent measured as above.

2. Width

- a. Street and alley asphalt widths depend on the total number of traveled lanes. Minimums are listed in Table 2.

(C) SHOULDER STANDARDS

- 1. Width –The width of improved shoulder will vary with the use and location. The improved shoulder shall consist of 6 inches of compacted road base at grade with the improved roadway surface. If parking is to be allowed by the City 8 foot shoulders shall be used. If parking is not allowed then 3 foot shoulders shall be used and the roadway shall be signed designating no parking. The decision to allow or not allow parking shall be made by the City of Salida.
- 2. Side Ditches – Side ditches shall be used in all cut sections. All roadside swales shall be sized to handle the historical 100-year storm flows tributary to the street, unless alternate routes for the major runoff are provided. Culvert sizes shall be designed to carry the 100-year historical flows. The slope from the edge of the shoulder to the bottom of the side ditch shall not exceed 3:1
- 3. Side Slopes – Side slopes shall not exceed 2:1, unless otherwise approved by the City Engineer. Where slopes equal to or greater than 2:1 are used, special provisions for erosion control and re-vegetation shall be made. Any proposal to deviate from a maximum 2:1 slope shall be accompanied by a soils study dealing with the slope treatment being proposed.

(D) MINIMUM CULVERT DIAMETERS

1. Size – All culverts installed shall be sized to handle the 100-year (historical) storm flows. The minimum allowable culvert size shall be 12 inches. All culverts shall be installed with flared end sections.
2. Cover – Minimum cover over all culvert shall be 12 inches from top of pipe to finish road grade, unless otherwise approved by the Public Works Director.
3. Type – For City drainage systems either density polyethylene (HDPE), RCP or corrugated metal pipe shall be used. For the purposes for driveway crossings, corrugated metal pipe is allowed

(E) RETAINING WALLS

Where necessary to meet required side slope grades, walls may be utilized.

1. Height – Retaining walls may not exceed 6 feet in height. If a greater height is needed, the wall must be stepped in maximum 6-foot increments with a minimum 4-foot shelf.
2. Location – Retaining walls may not be located closer than ten (10) feet from the traveled lanes (maximum separation is desired).
4. Design – Retaining wall must be designed by a Colorado Registered Professional Engineer and are subject to City review and approval.

(F) GUARDRAIL

Guardrail requirements shall be as specified in the State Highway Roadway Design Manual, latest edition. Corten steel shall be used for all guardrail installations unless otherwise approved by the City.

(G) SIGNS

All signs and street markings shall be designed, constructed and placed in accordance with the Manual of Uniform Traffic Control Devices, latest edition, unless otherwise approved by the City.

(H) PAVEMENT

1. General – Design of the pavement structure is the determination of the thickness of sub-bases, bases, and surfacing to be placed over sub grade soils. The basic purpose is the selection of the most suitable, available materials and their most advantageous use.

Pavement shall be designed for a 20-year life and designed by a Colorado Registered Professional Engineer.

2. Type of Surfacing – Both bituminous pavement and concrete are acceptable surfacing for use on streets in the City of Salida. The determination as to which type of surfacing to use is based on several factors including:
 - a. *Traffic loading and volume*
 - b. *Soils in the area*
 - c. *Weather*
 - d. *Performance of similar materials in the area*
 - e. *Economics or cost comparisons*
3. Thickness Design – thickness design shall be in accordance with the procedures as outlined in the CDOT Design Guide, latest edition. All new streets constructed in the City of Salida must be designed per these methods or other methods acceptable to the Public Works Director.
4. Minimum Base and Asphalt Thickness – The pavement design shall be used unless the designed thickness is less than the minimum allowable according to the street classification found in Table 2.

5. Plant Mix Pavement and Base Course – Plant mix pavement shall be State Highway Grading S Final top lift shall be SX. Base shall be State Highway Class 6. Sub-base shall be State Highway Class 5.
6. Compaction – All asphalt shall be compacted to 92% - 96% modified proctor.
7. Portland Cement Concrete Pavement – Concrete shall conform to State Highway requirements for Class “P”. “Fiber-mesh” fiber or approved substitute shall be added to the concrete, for strength, at the rate 1.5 pounds of fiber per cubic yard of concrete.

SECTION 4.00 - OTHER ELEMENTS OF DESIGN

(A) INTERSECTION

1. Minimum angle of intersection – Intersections shall approximate right angles as closely as possible. The minimum angle allowed for any type of intersection shall be 70 degrees.
2. Radius – All intersection shall have a paved radius on all four corners with minimum radius as in Table 1.
3. Cross Street Standard – All local streets intersecting an Arterial Street shall be constructed to Collector Street standards for a distance of 200 linear feet as measured from the edge of the Arterial ROW. This shall include street width (asphalt and base) and ROW width.
4. Grades – grades at intersections shall not exceed two percent (2%) at any point for 100 feet from the edge of the intersecting street, nor shall the grade exceed four percent (4%) overall for 200 feet from the same edge. Maximum grades may be increased beyond five percent (5%) for short distances in extreme terrain when approved by the City of Salida.
5. Separation
 - a. A proposed street and an existing street which intersect a common third street shall have a centerline no closer than one hundred twenty five feet (125’) from one another
 - b. Any two (2) proposed streets which intersect a common third street shall have a centerline no closer than two hundred fifty feet (250’) from one another.
 - c. No more than two (2) streets shall intersect at any point. A street shall have a minimum straight distance of one hundred feet (100’) from the intersection before it may be curved.
 - d. The length of local streets between intersections shall be a maximum of four hundred feet (400’).

(B) CUL-DE-SACS AND DEAD ENDS

1. Cul-de-sacs – Cul-de-sacs shall not exceed three hundred feet (300’) in length, unless it can be shown, to the satisfaction of the City, that a longer cul-de-sac would not create safety problems. Cul-de-sacs shall have a minimum paved radius of forty-five feet (45’) at the closed end. Cul-de-sacs shall be located at least forty feet (40’) from intersections.
2. Dead-end Streets – Dead-end streets (except for cul-de-sacs) shall be prohibited unless they are designed to connect with future streets on adjacent land that has not been platted. In such case a temporary turn around of at least 80 foot in diameter shall be provided. Use of a hammerhead type turn may be considered in special cases if approved by the Public Works Director.
3. General – Cul-de-sacs and Dead-end streets shall meet the minimum design standards as in the 2000 International Fire Code, Appendix D.

(C) PARKING SPACES

Size of parking stalls.

1. 30 degree to 90 degree—The minimum size for this type of parking shall accommodate an 18.5’ by 9’ rectangle within the stall.
2. Parallel spaces—Shall be 22’ as measured along the street and 8 feet wide
3. Handicap Stalls—Shall be a minimum 8’ wide by 18.5’ long, with a 5’ accessibility lane or 8’ accessibility lane for vans. Handicap stalls placed on an angle shall accommodate an 8’ wide by 18.5 ‘ long rectangle within the stall and accessibility lane as measured perpendicular to the stall.

(D) DRIVEWAYS (ACCESSES)

1. General – The term driveway or access are interchangeable terms and refer to the specific locations granted to properties adjacent to City ROW for the purpose of accessing the property through City ROW from City streets for all purposes including parking areas, dumpster enclosures, garages, etc.
2. Intent of Requirements – Driveway spacing and widths have been established for aesthetic, maintenance purposes, and safety reasons.
3. Requirements – A combination of these factors and others such as sight distance and safety has governed the following.
 - a. *Proximity to an intersection* – Driveways accessing City ROW near an intersection of an Arterial shall be a minimum of 50’ and for all other street classifications shall be a minimum of 35’ from the intersecting street ROW. When this spacing cannot be achieved (for example, due to lot size or topography) every effort will be made to place the access as far from the intersection as possible.
 - b. *Access to Single Family* – Only one access will be allowed to single family residences. More than one access will be considered by variance on corner lots.
 - c. *Widths of Driveways* – The width of any driveway connecting an off-street parking area with a public street, alley, or highway shall fall within the ranges as shown below, as measured within the City ROW

Single-family homes	9 feet minimum, 16 feet maximum
Duplexes or Multi-Units	9 feet minimum, 12 feet maximum (one way) 24 feet maximum (two way)
Commercial/Business	12 feet (one way), 24 feet (two way)
 - d. *Angle of intersection* – All driveways shall intersect the access street at 90 degrees.
 - e. *Access to Arterial Streets*- No driveways will be allowed onto arterial streets unless no other access to the lot exists. New subdivisions will not be approved on which driveways exit onto Arterial streets.
 - f. *Approved materials* – materials approved for driveways include Class 6 road base: 4000psi natural concrete (no color or stamp allowed); Gravel 1 inch or less; Asphalt.
4. *Exemption and Conformity* – Driveways which are to be repaved (existing driveways) can be done to the previous width. Existing gravel driveways, which are to be paved, shall conform to these requirements.

(E) PEDESTRIAN/BICYCLE FACILITIES

When pedestrian or bicycle pathway are required by the Planning Department, such facilities shall meet the following requirements.

Minimum sidewalk width shall be five feet, six feet on Collectors and Arterials

Minimum Bike pathway width shall be ten feet wide with one foot compacted road base shoulders 6" thick on each side.

Minimum section for both shall be either four-inch concrete with three inch compacted road base on a prepared subgrade or three inches of asphalt with six inches of road base on a prepared subgrade.

Concrete shall comply with requirement in Section 3, A, 5.

Pedestrian/bicycle pathways shall have handicap ramps in compliance with ADA standards.

Reduced widths for bike paths may be considered where ROW widths are limited.

(F) TEMPORARY UNPAVED STREETS

Under certain circumstances, the Public Works Director may allow either a delay of final paving of a new street, or a delay in the final lift, until the following construction season to allow sufficient time for roadway stabilization or until a certain percentage of build out occurs. In those cases, all street construction up to and including base work shall be completed. Unpaved streets shall be graded to a three percent crown and then regarded and compacted as required by these standards prior to paving. Unpaved streets will not be accepted by the City for maintenance purposes.

(G) EROSION CONTROL

1. Introduction – Care shall be taken in designing streets to minimize the total area disturbed, as well as to have all disturbed areas replanted to prevent future erosion.
2. Developer/contractor must follow all State regulations concerning stormwater and erosion control.

An acceptable erosion control plan must be approved by the City of Salida and utilized by the Contractor to prevent excessive erosion during and after construction. If, in the opinion of the Public Works Director, adequate measures to control erosion are not being taken, the contractor may be ordered to stop all work within City ROW until satisfactory arrangements for control are made.

3. Reseeding – All areas disturbed within City ROW during street construction shall be covered with 4 inches of topsoil and reseeded with a native seed mix that is certified free of noxious weeds and approved by the City following completion of the Work.

The mix shall be applied to a smooth base area free from foreign matter and excessive amount of rock (three inch diameter or larger). The mix shall be applied at a rate and in a manner as recommended by the seed supplier. Following seeding, all areas shall be fertilized.

Immediately following seeding and fertilizing mulch areas with native hay at a rate of two tons per acre. The hay shall be mechanically crimped into the soil or hand tilled.

4. Steep Slopes – Any slopes 2:1 or greater shall receive, in addition to all requirements above, an approved soil erosion blanket, approved by the Public Works Director. Slopes greater than 2:1 require specific engineering design and are subject to approval by the City.

(H) Other

Any improvements required on any portion of an existing street, which serves as the access for a new development, shall be designed and paid for by the developer of that new development. New and existing roadways shall be designed or improved to handle the additional traffic volume generated.

SECTION 5.00 - ACCEPTANCE OF NEW STREETS

(A) AUTHORIZATION TO PLACE IN SERVICE

Newly installed streets may be placed in service upon completion of the installation, testing, and inspection outlined previously in this specification, receipt and acceptance of the As-Built Drawings by the City, and upon issuance of the Certificate of Completion by the City.

(B) CONTRACTOR'S WARRANTY

The Contractor shall warrant his work to be free from defects in materials and workmanship for a period of not less than one (1) year (the Acceptance Period). The Contractor may request release from Warranty responsibility one year after the date of signature on the Certificate of Completion.

(C) FINAL INSPECTION

At the end of the one (1) year Acceptance Period, and upon request by the Contractor, the City and the Contractor shall jointly observe the work. The City may make such tests and inspections as he deems necessary, consistent with these specifications. Any defects in the system resulting from defective materials, poor workmanship or any other cause attributable to the Contractor's work shall be corrected by the Contractor, to the satisfaction of the City, at the Contractor's expense.

(D) ACCEPTANCE BY THE CITY

After the Final Inspection, and upon satisfactory correction of any deficiencies by the Contractor, the City shall issue written "NOTICE OF ACCEPTANCE". At that point the City assumes responsibility for that pipeline, and the Contractor shall be relieved of further responsibility for the work.

(E) WARRANTY CONTINUES UNTIL NOTICE OF ACCEPTANCE:

Responsibility to initiate the Final Inspection procedure resides with Contractor. In the event that the Contractor fails to request a Final Inspection, the Contractor's Warranty shall continue to run until such a time as the work is inspected by the City, and a NOTICE OF ACCEPTANCE is issued by the City, or as terminated in 13(G).

(F) REMEDY FOR FAILURE TO HONOR WARRANTY:

Should a Contractor fail to honor his warranty obligations by refusing or neglecting to repair defective work during the one year warranty period, said Contractor shall forfeit eligibility to bid upon City work for a period of three (3) years. The City representative may, at his discretion, refuse to accept for inclusion into the City utility system any private work constructed by that Contractor during that period.

(G) AUTOMATIC ACCEPTANCE BY THE CITY:

Absent action by the Contractor requesting a Final Inspection, or by the City requesting Warranty work, use of the system by the City for a period of three (3) years from the date of the Certificate of Completion shall be considered de facto evidence that the system was satisfactorily constructed. In the absence of known defects requiring remedial work, the Contractor's warranty responsibility for the work shall automatically terminate three (3) years from the date of the Certificate of Completion.

SECTION 6.00 - MODIFICATION OF THIS SPECIFICATION

(A) CHANGES

The City of Salida may edit, amend, improve, or change these Specifications from time to time, as the Public Works Director shall deem necessary and in the best interests of the City. Plans submitted for review subsequent to the effective date of any revisions shall conform to the revised specification.

(B) PROHIBITION AGAINST RETROACTIVE APPLICATION

Changes to the Specifications shall not be applied retroactively to plans already approved for construction.

TABLE 1
INTERSECTION DESIGN

<u>Design Topic</u>	<u>Street Type</u>			
	<u>Alley</u>	<u>Local</u>	<u>Collector</u>	<u>Arterial</u>
Minimum Curb or Edge of Asphalt Radius (feet)	5	10	15	20

TABLE 2

Street Type	Minimum Dedicated ROW (FT) see note 1	Minimum Paved Width (FT)	Minimum Allowable Base and Asphalt see notes 2,4
ARTERIAL	100	36 foot paved	4 inch asphalt 5 inch base
COLLECTOR	80	36 foot paved	3 inch asphalt 4 inch base
LOCAL (COMMERCIAL)	60	30 foot paved	4 inch asphalt 5 inch base
LOCAL (RESIDENTIAL)	60	24 foot paved	3 inch asphalt 4 inch base
ALLEYS	20	20 foot paved	3 inch asphalt 4 inch base
CUL-DE-SACS	75 radius	45 foot radius paved	3 inch asphalt 4 inch base

PRIVATE STREETS
(see note 3)

N/A

N/A

N/A

NOTES:

1. Required right-of-way may be increased in some cases by the Public Works Director
2. Asphalt mat to be placed in two lifts
3. Private streets are not allowed in the City of Salida
4. Paving fabric may be required, depending on soils testing.

TABLE 3

Street Type	Design Speed (MPH) <small>(See Note 1)</small>	Minimum Centerline Radius (FT)	Minimum Tangent Between Curves (FT)
Local	25	75	50
Collector	35	300	150
Arterial	35	300	150

NOTES:

1. Design speed is not necessarily posted speed

City of Salida, Colorado
Department of Public Works

STREET and CONCRETE
CONSTRUCTION STANDARDS

TABLE OF CONTENTS

GENERAL NOTES

GN-01 General Notes

CONCRETE

C-01 Drive Over Curb & Gutter
C-02 30" Curb and Gutter
C-02a 18" Curb and Gutter
C-03 Typical Driveway Details
C-04 Typical Valley Pan at Intersections
C-05 Curb Ramps
C-06 Detectable Warnings
C-07 Vertical Curb, Gutter, Parkway and Sidewalk
(typical detail)

STREET

ST-01 Existing Street Improvements
ST-02 New Street Construction – Typical
ST-03 Typical Overlay Section
ST-04 Typical Asphalt Patches
ST-05 Concrete Collar Details

STORM DRAIN

SD-01 Storm Drain Manhole
SD-02 Typical Trench Drain
SD-03 Storm Drain Curb Inlet
SD-04 Valley Pan Inlet
SD-05 Area Drain

GENERAL NOTES

1. All work shall be done in accordance with the technical specifications and project drawings applicable to the project and shall conform to the City of Salida's road and sidewalk standards, Section 9-11-2 of the Land Use Code and these construction standards. The Standard Specifications for Road and Bridge Construction of the Colorado Department of Transportation, dated 2005 (or most current) shall govern all work not covered by approved project specifications and drawings.
2. Unless otherwise specified, subgrade and base under all asphalt and concrete will conform to the following:
 - A. Subgrade: Prepare and compact to achieve a minimum of 95% standard proctor density in accordance with ASTM D698/AASHTO T-99 within +/-2% of the optimum moisture content.
 - B. Aggregate Road Base: Material shall be Class 6 meeting the requirements of CDOT Section 703.03
 - C. Class 6 aggregate base shall be placed in maximum 6 inch lifts and shall be compacted to a minimum of 95% standard proctor density within +/-2% of the optimum moisture content
 - D. Where paving is not required per Section 9-8-4-A of the Land Use Code (or as approved by the City), a minimum of 4" compacted Class 6 aggregate base and 2" gravel (3/4" crushed material) surfacing shall be provided
3. All concrete shall be 4000psi and shall meet the following requirements:
 - A. Contractor shall submit for review the proposed mix design.
 - B. An approved curing compound shall be used on all flat work.
 - C. Maximum spacing of contraction joints in curb and gutter shall be 10 feet.
 - D. Sidewalks, drive aprons and handicap ramps – contraction joints shall provide panels as nearly square as practical. In rectangular panels, the long side shall be no longer than 1 ½ times as long as the short side.
 - E. All sidewalk contraction joints shall be tooled unless saw cut or strip lock is approved. The groove of contraction joints shall be ¼ of the slab thickness. The radius at the top of the groove shall be as small as possible.
 - F. Contraction joints shall be provided at "re-entrant" corners. Fixed objects isolated within an individual section shall be isolated from the main slab with expansion material. Two joints shall radiate from the object and shall be perpendicular to the joints of the individual section.
 - G. Expansion joints shall be installed in sidewalks at approximately 100; intervals.
 - H. Expansion joints shall be installed when abutting concrete or a fixed structure unless shown otherwise in the project drawings or as approved by the City Public Works Director or City Engineer.
 - I. Expansion joint material shall be ½" thick and shall extend the full depth of the contact surface.
4. All asphalt work shall be performed in strict accordance with Note 1 above. No work shall be started on the project until the contractor has submitted for review a satisfactory job mix formula based upon tests of the materials to be furnished
5. The City may provide some testing for their own benefit in addition to testing required by the Owner/Developer and/or Contractor. Developer/Contractor shall notify Owner and/or City sufficiently in advance of operations and shall provide access to the work to be tested. If tests fail to meet specified requirements, the contractor shall promptly remedy such deficiencies, and shall be responsible to the owner for the costs of any retesting deemed necessary to verify correction of the deficiency. Contractor shall be responsible for location of all utilities prior to beginning work by contacting UNCC (1.800.922.1987) and utility owners.

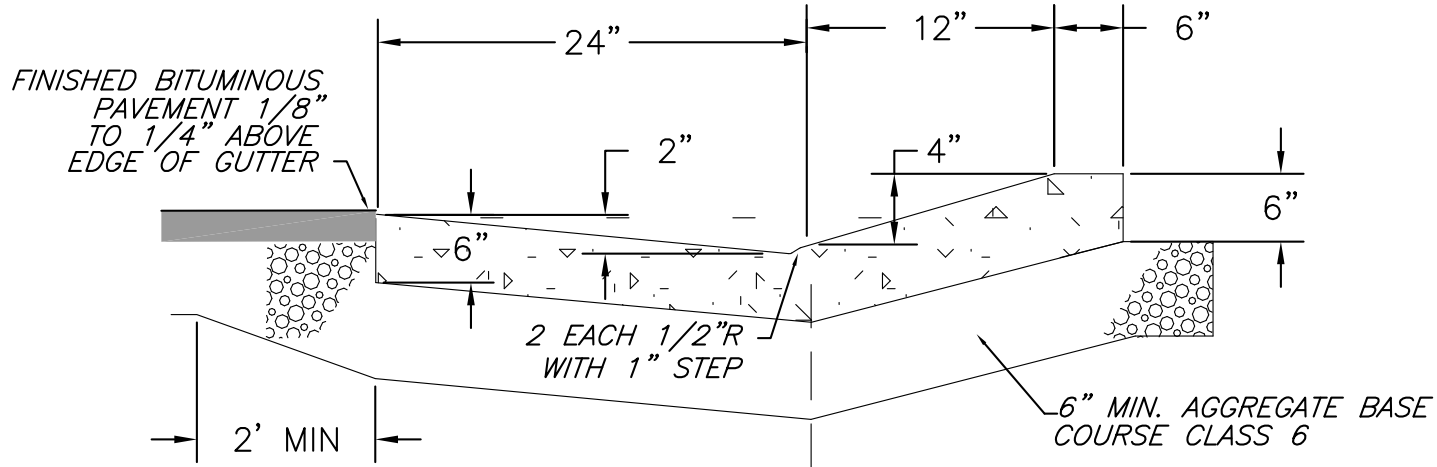

DRIVE OVER CURB & GUTTER

NOTE:
PROVIDE FIBERMESH REINFORCEMENT IN CONCRETE MIX AT 1 1/2 # PER CU.YD.

N.T.S.

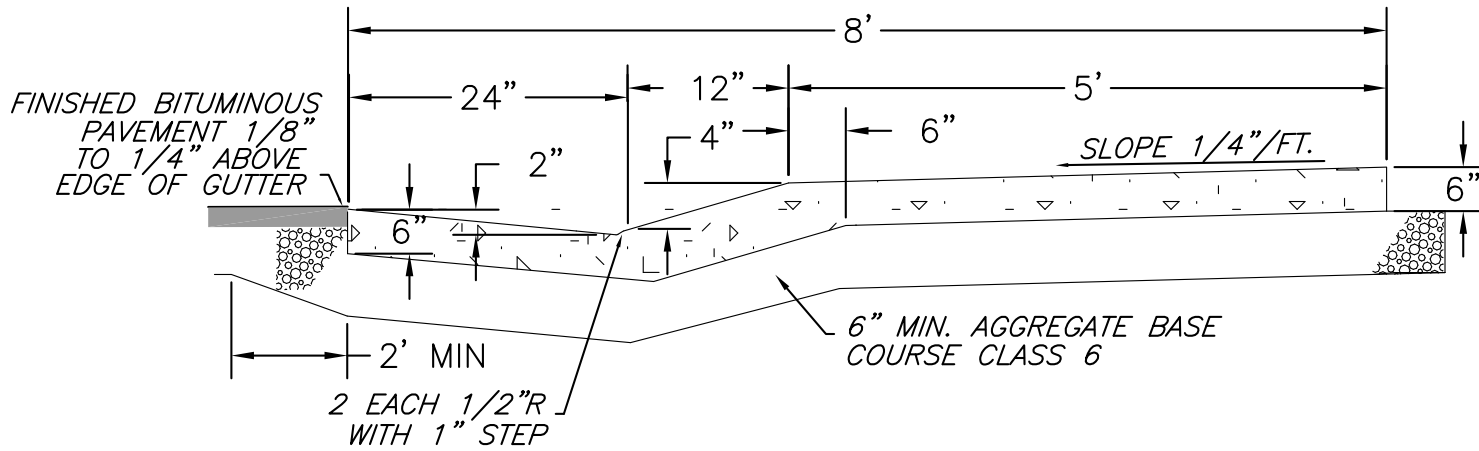

DRIVE OVER CURB & GUTTER WITH ATTACHED SIDEWALK

N.T.S.

DETAIL

DRIVE OVER CURB AND GUTTER DETAILS

CITY OF SALIDA PUBLIC WORKS DEPARTMENT

SCALE
NOT TO SCALE

FILE
DWG: C-01

LATEST REVISION
6/19/2009

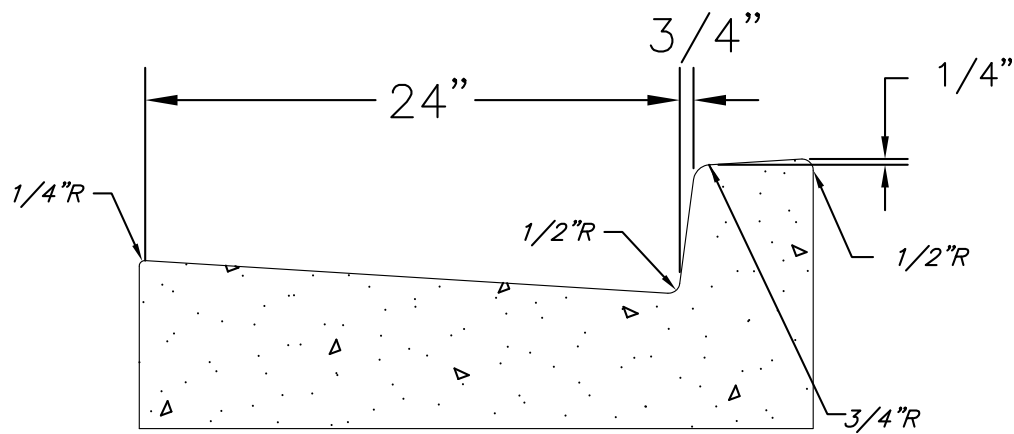

30 "STANDARD CURB & GUTTER

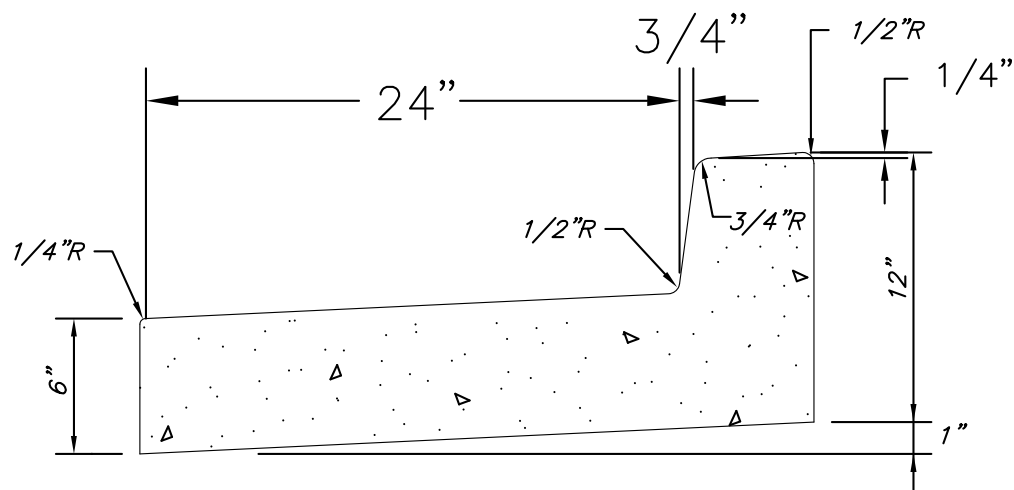

30" INVERTED CURB & GUTTER

<small>DETAIL</small> 30" CURB AND GUTTER DETAILS (STANDARD)	CITY OF SALIDA PUBLIC WORKS DEPARTMENT		
	<small>SCALE</small> NOT TO SCALE	<small>FILE</small> DWG: C-02	<small>LATEST REVISION</small> 6/19/2009

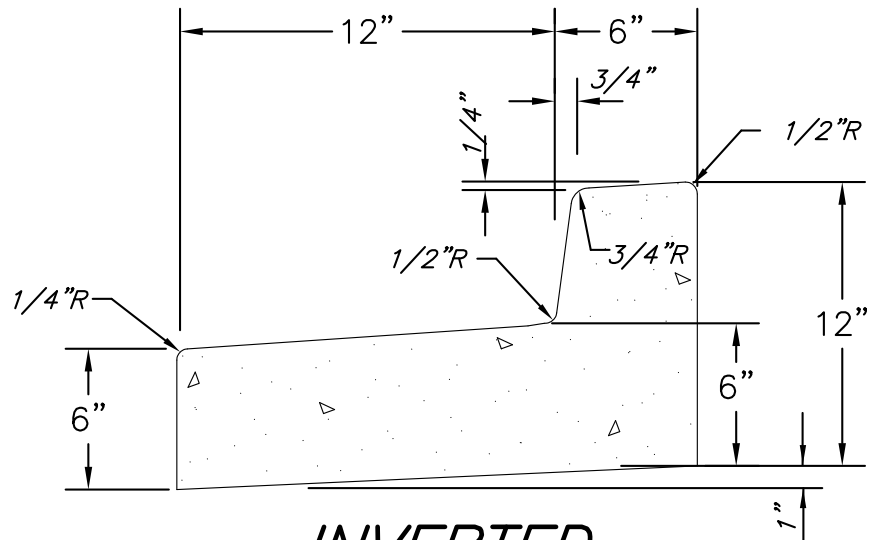

**INVERTED
18" CURB & GUTTER**

SCALE: 1 1/2" = 1'-0"

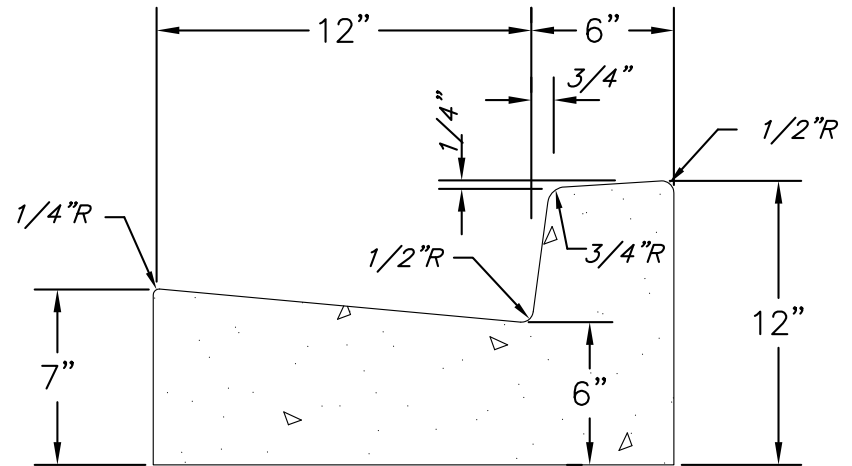

18" CURB & GUTTER

SCALE: 1 1/2" = 1'-0"

NOTE:
USE ONLY WITH WRITTEN
PUBLIC WORKS APPROVAL

DETAIL

**18" CURB AND GUTTER
DETAILS**

CITY OF SALIDA PUBLIC WORKS DEPARTMENT

SCALE
NOT TO SCALE

FILE
DWG: C-02A

LATEST REVISION
6/19/2009

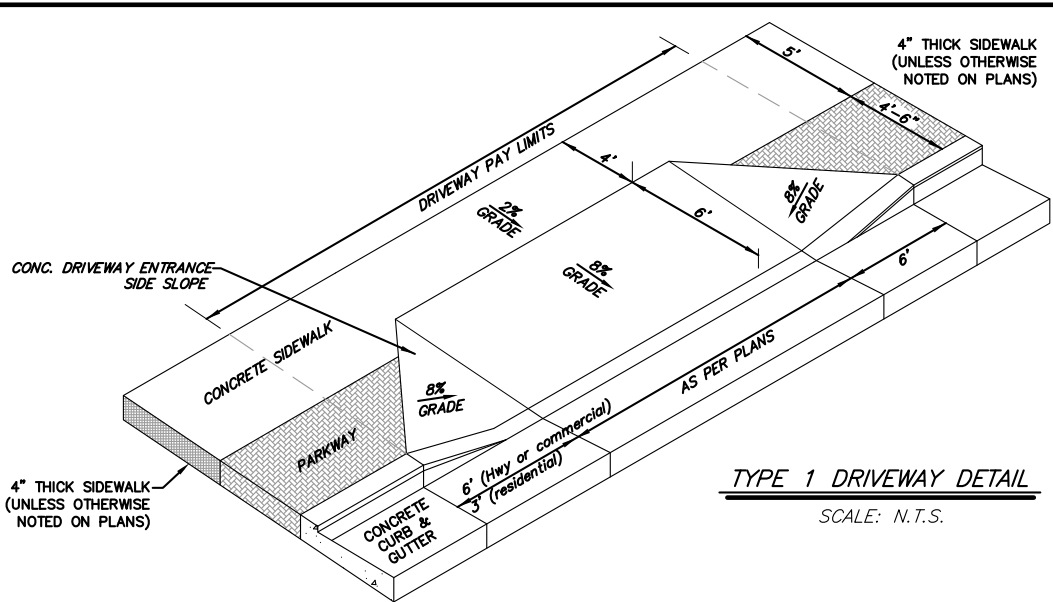

TYPE 1 DRIVEWAY DETAIL
SCALE: N.T.S.

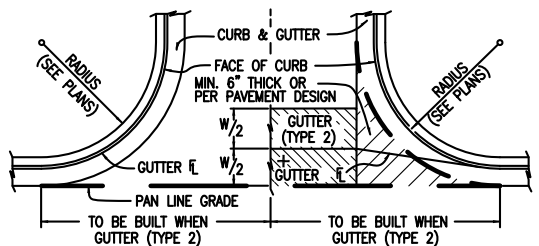

TO BE BUILT WHEN GUTTER (TYPE 2) IS NOT REQUIRED TO BE BUILT WHEN GUTTER (TYPE 2) IS REQUIRED

☐ THIS AREA SHALL BE POURED MONOLITHICALLY WITH CURB AND GUTTER AND PAID FOR AS "CONCRETE PAVEMENT."

+ FLOW LINE LOCATION WILL BE ESTABLISHED BY W/2 SHOWN ON PLANS.

CONSTRUCTION OF CONCRETE GUTTERS AT INTERSECTION

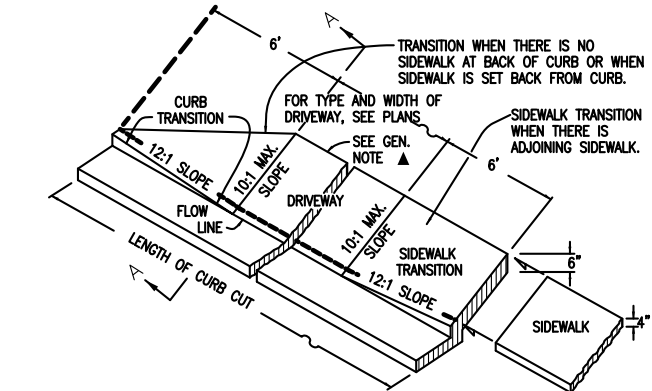

CURB CUT FOR DRIVEWAYS

GENERAL NOTES

- ON CURVES 3 DEGREES OR SHARPER, CURBS AND/OR GUTTERS ARE TO BE PLACED ON THE ARC OF THE CURVE UNLESS OTHERWISE NOTED ON THE PLANS. A MAXIMUM CHORD LENGTH OF 10 FEET MAY BE USED WHEN THE DEGREE OF CURVE IS LESS THEN 3 DEGREES.
 - CONCRETE SHALL BE CLASS B.
 - PROFILE GRADE OF CURBS AND GUTTERS SHALL BE LOCATED AT THE FLOW LINE.
- ▲ EXPANSION JOINTS SHALL BE INSTALLED WHEN ABUTTING EXISTING CONCRETE OR FIXED STRUCTURE. EXPANSION JOINT MATERIAL SHALL BE 1/2 IN. THICK AND SHALL EXTEND THE FULL DEPTH OF CONTACT SURFACE.
- ① GUTTER CROSS SLOPES SHALL BE 1/2 IN./FT. WHEN DRAINING AWAY FROM CURB AND 1IN./FT. WHEN DRAINING TOWARD CURB.
- * CONCRETE SHALL CONTAIN 1.5 POUNDS PER CUBIC YARD APPROVED POLYPROPYLENE FIBERS AND HAVE A NOMINAL AGGREGATE SIZE OF 3/8 IN.

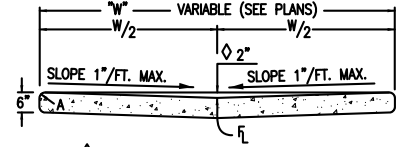

GUTTER TYPE 2

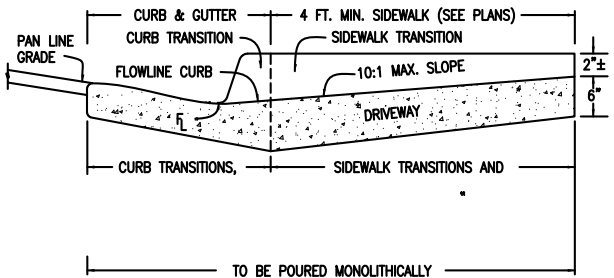

CONCRETE PAVEMENT (DRIVEWAYS)

SECTION A-A

DETAIL

TYPICAL DRIVEWAY DETAILS

CITY OF SALIDA PUBLIC WORKS DEPARTMENT

SCALE
NOT TO SCALE

FILE
DWG: C-03

LATEST REVISION
6/19/2009

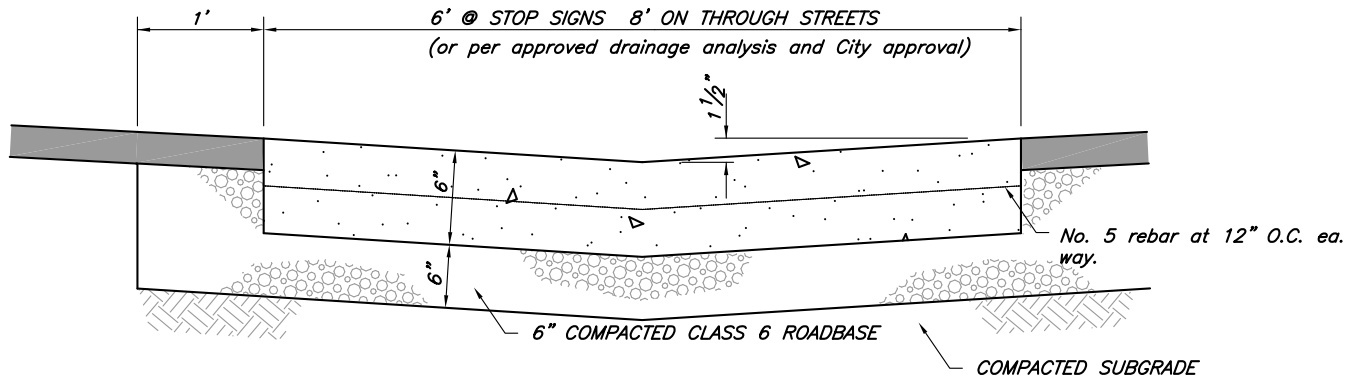

VALLEY PAN DETAIL

SECTION A-A

GUTTER SLOPES SHALL DRAIN AWAY FROM CURB.

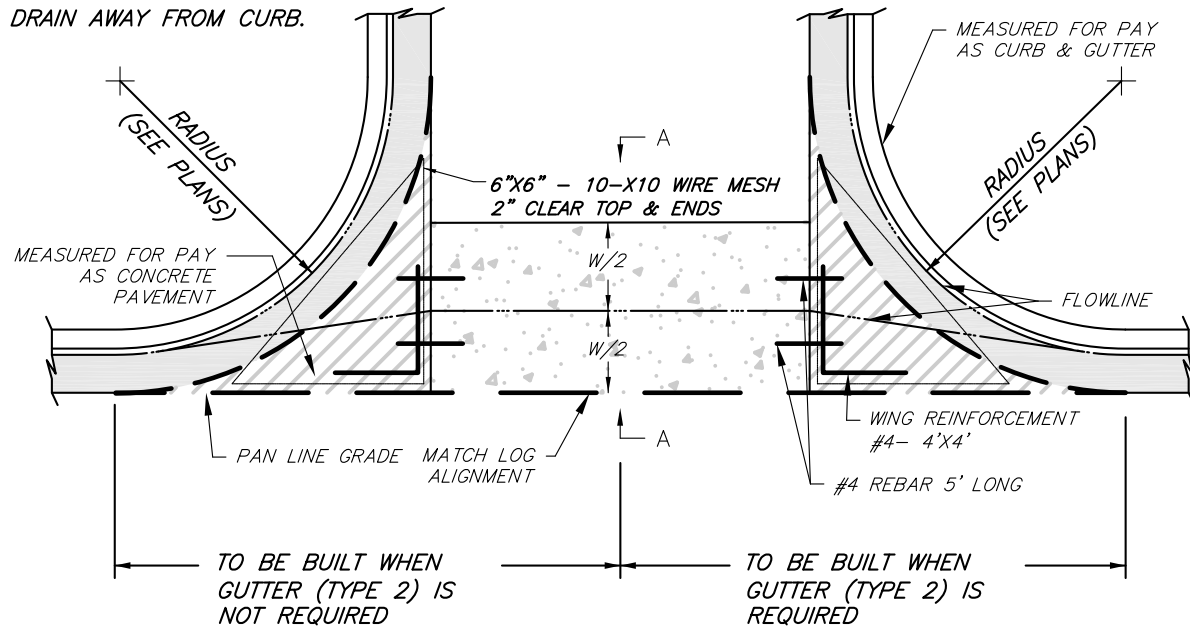

 THIS AREA SHALL BE Poured MONOLITHICALLY WITH CURB AND GUTTER AND PAID FOR AS "CONCRETE PAVEMENT."

+ FLOW LINE LOCATION WILL BE ESTABLISHED BY W/2 SHOWN ON PLANS.

NOTE:

1. CURB RADIUS FOR CITY STREETS VARIED BY LOCATION, TO BE APPROVED BY PUBLIC WORKS DEPT.

2. CURB RADIUS FOR CDOT ROW'S USE CDOT STANDARDS.

CONSTRUCTION OF CONCRETE GUTTERS AT INTERSECTION

DETAIL

VALLEY PAN AT INTERSECTION

CITY OF SALIDA PUBLIC WORKS DEPARTMENT

SCALE
NOT TO SCALE

FILE
DWG: C-04

LATEST REVISION
6/19/2009

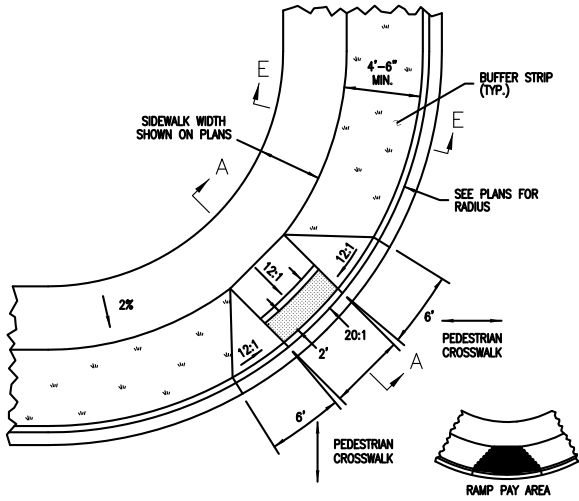

SIDEWALK RAMP TYPE 3A
PLAN

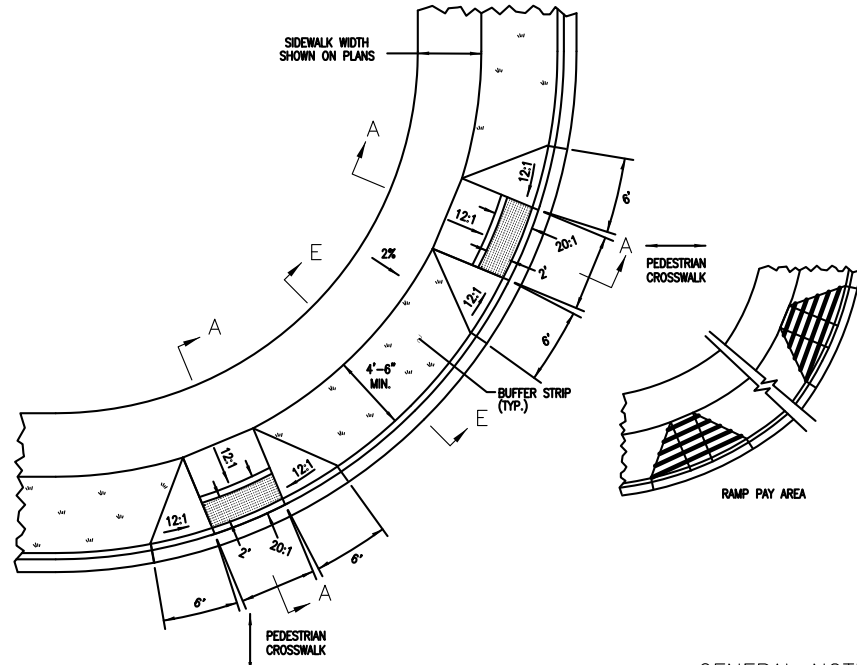

SIDEWALK RAMP TYPE 3B
PLAN

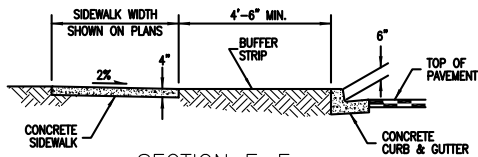

SECTION E-E

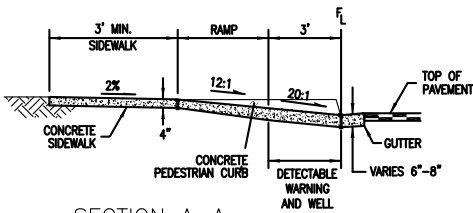

SECTION A-A

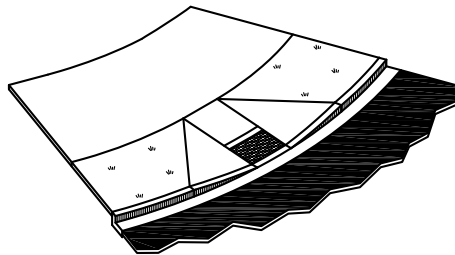

ISOMETRIC VIEW

GENERAL NOTES

1. AVOID PLACING DRAINAGE STRUCTURES, TRAFFIC SIGNAL EQUIPMENT, JUNCTION BOXES, OR OTHER OBSTRUCTIONS IN FRONT OF RAMP ACCESS AREAS.
2. RAMP SLOPES SHALL NOT BE STEEPER THAN 12:1. THE DETECTABLE WARNING AND WELL AREA SLOPES SHALL NOT BE STEEPER THAN 20:1.
3. CONSTRUCTION OF THE CONCRETE PEDESTRIAN CURB TO BE INCLUDED IN THE COST OF THE CURB RAMP.

DETAIL

CURB
RAMPS

CITY OF SALIDA PUBLIC WORKS DEPARTMENT

SCALE
NOT TO SCALE

FILE
DWG: C-05

LATEST REVISION
6/19/2009

SIDE CROSS SECTION VIEW OF
DETECTABLE WARNING, WELL, CURB, AND GUTTER

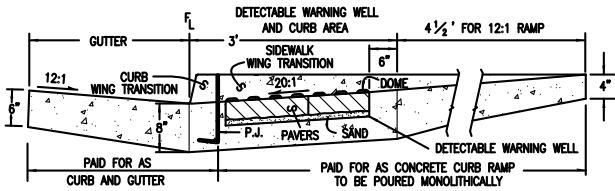

DETAIL FOR TYPES 1 AND 3 CURB RAMP

P.J. = PERMISSIBLE JOINT WITH EPOXY-COATED DEFORMED NO. 4 BY 18 IN. BARS CONFORMING TO AASHTO M 284 AT 18 IN. SPACING.

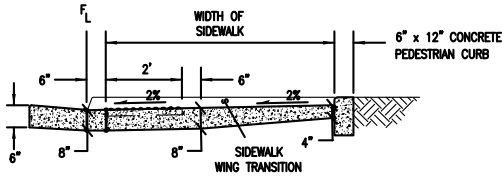

DETAIL FOR TYPE 2 CURB RAMP

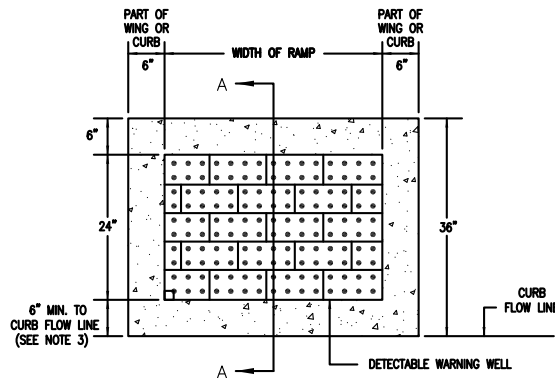

PLAN VIEW OF
DETECTABLE WARNING AND WELL
(PAVERS NOT DRAWN TO SCALE)

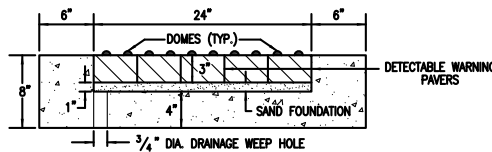

SECTION A-A

THE TOP DIAMETER OF THE TRUNCATED DOMES SHALL BE 50% TO 65% OF THE BASE DIAMETER

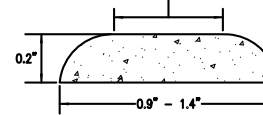

ELEVATION VIEW

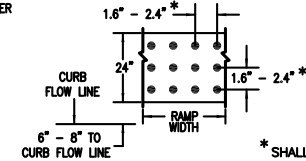

PLAN VIEW

DOMES AND DETECTABLE WARNING DETAILS

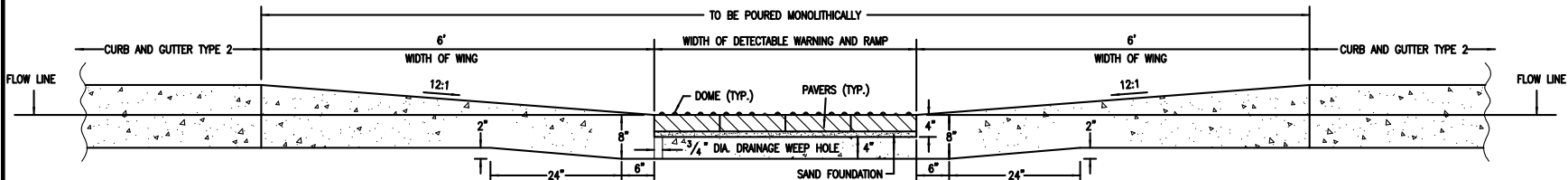

FRONT SECTION VIEW OF
DETECTABLE WARNING, WELL, CURB, AND GUTTER

CAST-IN-PLACE DETECTABLE WARNING SURFACE TILE

- A. PROVIDE CAST-IN-PLACE TACTILE TILES AND ACCESSORIES AS PRODUCED BY A SINGLE MANUFACTURER.
- B. PRODUCT SHALL MEET THE AMERICANS WITH DISABILITIES ACT (ADA) FOLLOWING REQUIREMENT: PROVIDE TACTILE WARNING SURFACES WHICH COMPLY WITH THE DETECTABLE WARNING ON WALKING SURFACES SECTION OF THE ADA (TITLE 49 CFR TRANSPORTATION, PART 37.9 STANDARDS FOR ACCESSIBLE TRANSPORTATION FACILITIES, APPENDIX A, SECTION 4.29.2 DETECTABLE WARNINGS ON WALKING SURFACES.) or most current version/revisions.
- C. VITRIFIED POLYMER COMPOSITE (VPC) CAST-IN-PLACE PANELS SHALL BE AN EPOXY POLYMER COMPOSITION WITH AN ULTRA VIOLET COATING EMPLOYING ALUMINUM OXIDE PARTICLES IN THE TRUNCATED DOMES.
- D. CAST-IN-PLACE TACTILE PANELS SHALL BE GUARANTEED IN WRITING FOR A PERIOD OF FIVE YEARS FROM DATE OF FINAL COMPLETION. THE GUARANTEE INCLUDES DEFECTIVE WORK, BREAKAGE, DEFORMATION, FADING AND CHALKING OF FINISHES, AND LOOSENING OF PANELS.

DETAIL

DETECTABLE
WARNING PAD

CITY OF SALIDA PUBLIC WORKS DEPARTMENT

SCALE
NOT TO SCALE

FILE
DWG: C-06

LATEST REVISION
6/19/2009

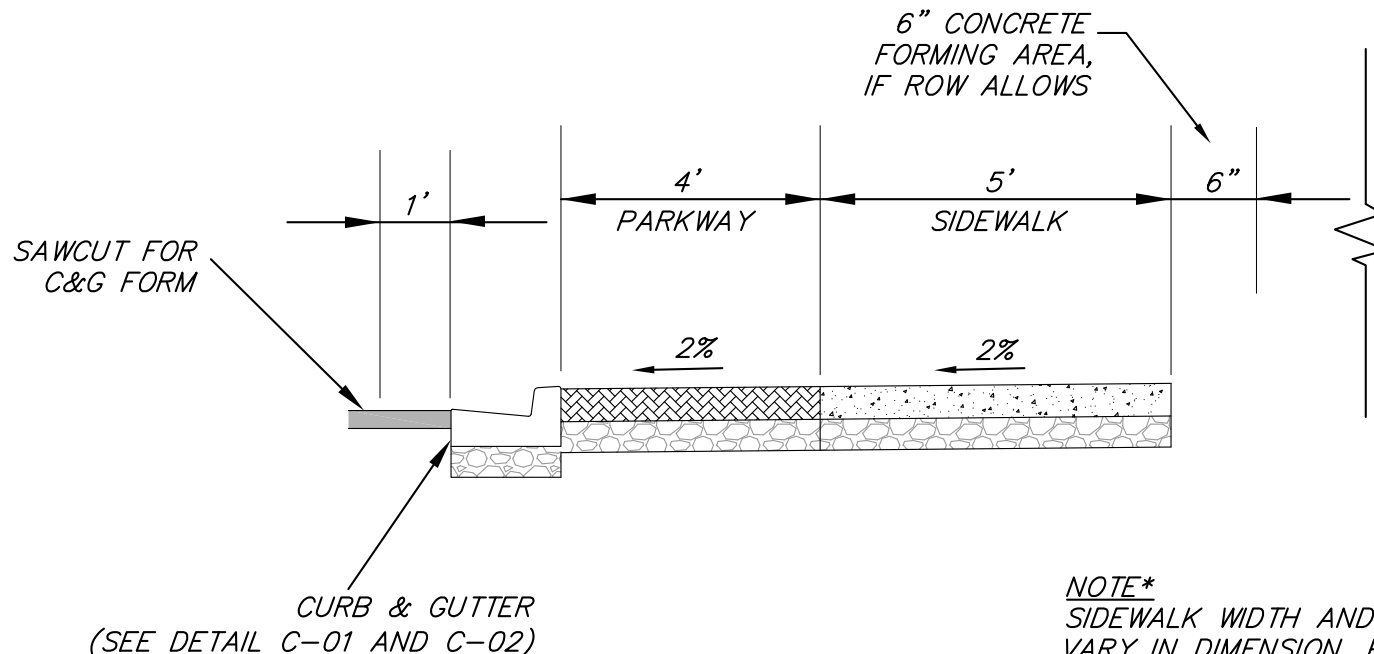

NOTE*
 SIDEWALK WIDTH AND PARKWAY MAY VARY IN DIMENSION, PER APPROVAL BY THE CITY PLANNING AND PUBLIC WORKS DEPARTMENTS – ADVANCE APPROVAL REQUIRED.

PROPOSED PARKWAY/SIDEWALK TYPICAL SECTION
 SCALE: N.T.S.

<small>DETAIL</small> VERTICAL CURB, GUTTER, PARKWAY & SIDEWALK	CITY OF SALIDA PUBLIC WORKS DEPARTMENT		
	<small>SCALE</small> NOT TO SCALE	<small>FILE</small> DWG: C-07	<small>LATEST REVISION</small> 6/19/2009

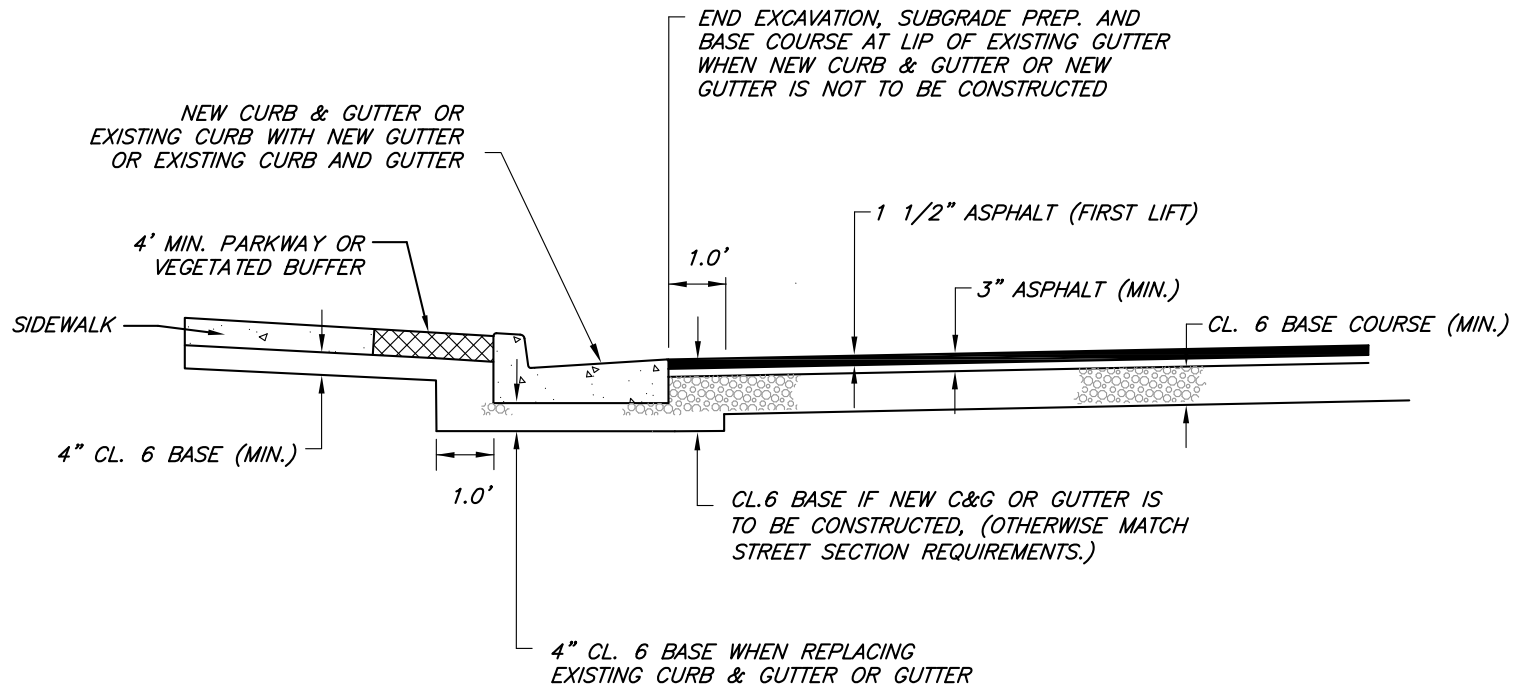

TYP. ROAD CROSS-SECTION

NOTES:

1. THIS STANDARD ONLY APPLIES TO RECONSTRUCTION OF AN EXISTING STREET WHERE ADEQUATE AGGREGATE BASE EXISTS.
2. AFTER REMOVALS AND UNCLASSIFIED EXCAVATION, PROOF ROLL AND REMOVE LOW DENSITY/UNSUITABLE MATERIAL, IF ANY, BELOW TOP OF SUBGRADE.
3. REPLACE LOW DENSITY/UNSUITABLE MATERIAL WITH CLASS 6 AGGREGATE BASE.
4. PREPARE EXISTING SUBGRADE TO ACHIEVE 95% AASHTO T-180 AT ± 2% OPTIMUM MOISTURE CONTENT.
5. USE CLASS 6 AGGREGATE BASE TO RAISE SUBGRADE LEVEL AS REQUIRED. GENERALLY GRADE CHANGES WILL NOT BE SIGNIFICANT.
6. COMPACT CLASS 6 BASE COURSE TO 95% AASHTO T-180 AT ± OPTIMUM MOISTURE CONTENT IN MAXIMUM 6 INCH LIFTS.
7. CLASS 6 BASE COURSE QUANTITIES UNDER STREET SECTIONS ARE NOT KNOWN, SUBGRADE SOILS INVESTIGATION REQUIRED. A MINIMUM OF 1" THICKNESS IS ANTICIPATED AS A LEVELING COURSE. 3" OR MORE MAY BE REQUIRED IN SOME AREAS FOR GRADE ADJUSTMENTS AND TO ACCOUNT FOR OVER-EXCAVATION OF LOW DENSITY/UNSUITABLE SUBGRADE AREAS.
8. ALL ASPHALT SHALL BE PLACED IN TWO 1-1/2" LIFTS EXCEPT WHERE APPROVED OTHERWISE IN PROJECT SPECIFICATIONS AS SINGLE 3" LIFT.

<p>DETAIL</p> <p>EXISTING STREET IMPROVEMENTS</p>	<p>CITY OF SALIDA PUBLIC WORKS DEPARTMENT</p>		
	<p>SCALE</p> <p>NOT TO SCALE</p>	<p>FILE</p> <p>DWG: ST-01</p>	<p>LATEST REVISION</p> <p>6/19/2009</p>

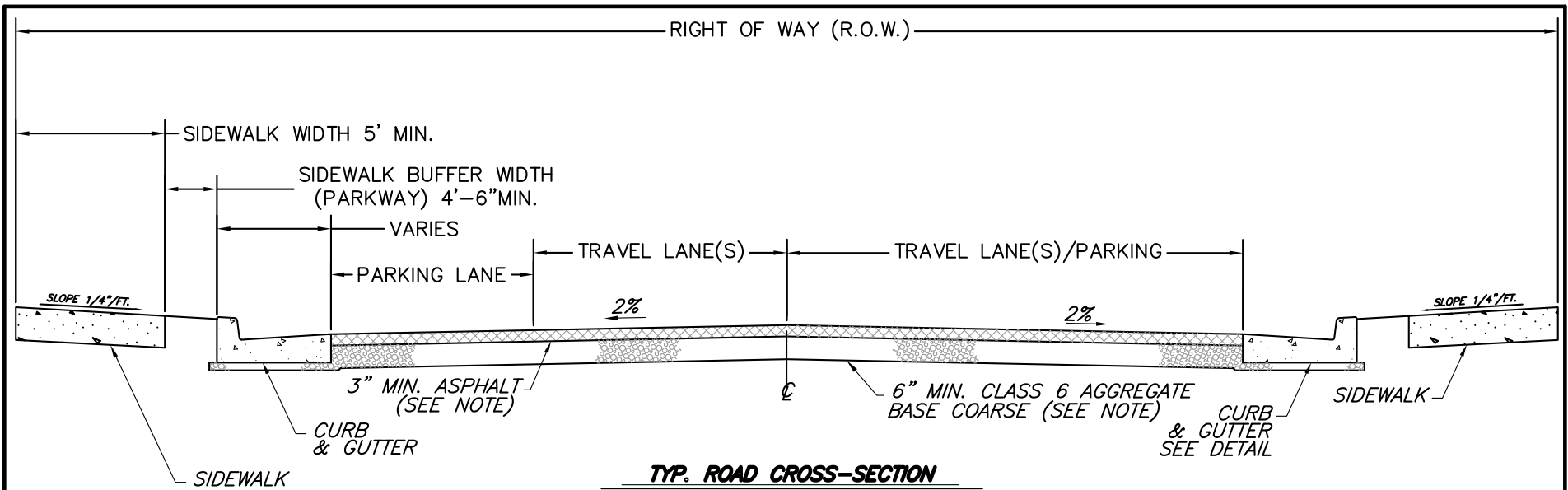

N.T.S.

ROAD TYPE	ROW WIDTH	TRAVEL LANE(S) WIDTHS	PARKING LANE WIDTH	TRAVEL LANE WIDTH	SIDEWALK WIDTH	SIDEWALK/STREET BUFFER	ASPHALT/ROADBASE THICKNESS (INCHES)
ARTERIAL STREET	100 FEET	2 EA - 12 FEET	8 FEET	32 FEET	6 FEET	4'-6"	5" ASPH / 6" BASE
COLLECTOR STREET	80 FEET	12 FEET	8 FEET	20 FEET	6 FEET	4'-6"	5" ASPH / 6" BASE
LOCAL STREETS/CUL-DE-SAC:							
WITH ON STREET PARKING #2	60 FEET	12 FEET	8 FEET	20 FEET	5 FEET	4'-6"	3" ASPH / 6" BASE
WITHOUT ON STREET PARKING	60 FEET	12 FEET	--	12 FEET	5 FEET	4'-6"	3" ASPH / 6" BASE
ALLEY	20 FEET	10 FEET	--	20 FEET	--	--	6" BASE

NOTES:

- #1 ASPHALT AND BASE DEPTHS IDENTIFIED ARE MINIMUMS. PROVIDE DEPTHS AS DETERMINED BY SOILS REPORT AND ENGINEERS DESIGN BASED UPON PROJECTED TRAFFIC CONDITIONS, LOADING AND SOIL STRENGTHS.
- #2 LOCAL STREET OR CUL-DE-SAC WITHOUT ON STREET PARKING MUST BE APPROVED BY THE CITY BY VARIANCE REQUEST.
- #3 ALL LOCAL STREETS SHALL INCLUDE ON-STREET PARKING.
- #4 PROVIDE PROFESSIONAL ENGINEERS STAMPED DRAWINGS AND DESIGN REPORT TO PW DEPT. FOR APPROVAL.

<p>DETAIL</p> <h1 style="margin: 0;">TYPICAL NEW STREET SECTIONS</h1>	<h2 style="margin: 0;">CITY OF SALIDA PUBLIC WORKS DEPARTMENT</h2>		
	<p>SCALE</p> <p>NOT TO SCALE</p>	<p>FILE</p> <p>DWG: ST-02</p>	<p>LATEST REVISION</p> <p>6/19/2009</p>

EXISTING ASPHALT SURFACE TO BE
PATCHED, CLEANED AND PREPARED FOR
TACKCOAT AND ASPHALT OVERLAY

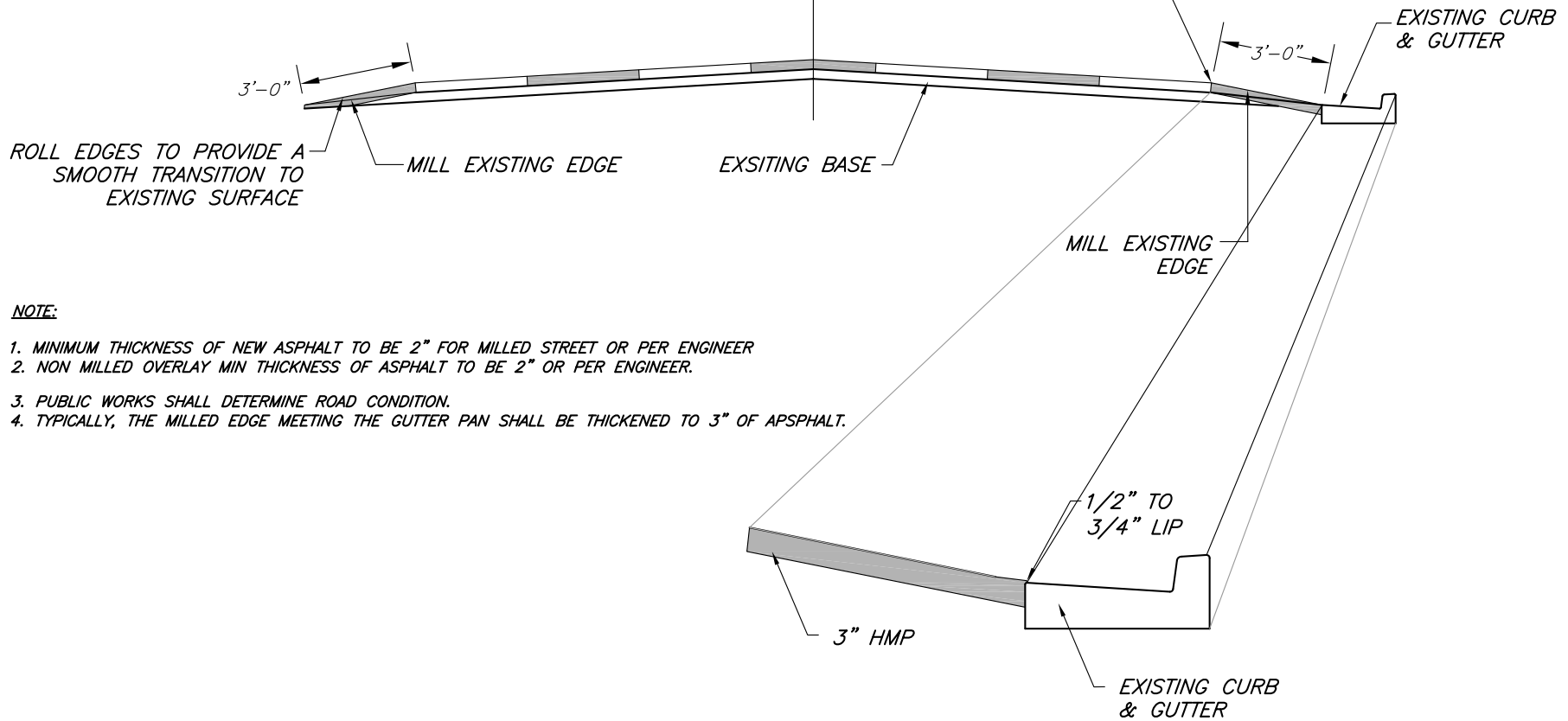

DETAIL

TYPICAL OVERLAY
SECTION

CITY OF SALIDA PUBLIC WORKS DEPARTMENT

SCALE

NOT TO SCALE

FILE

DWG: ST-03

LATEST REVISION

6/19/2009

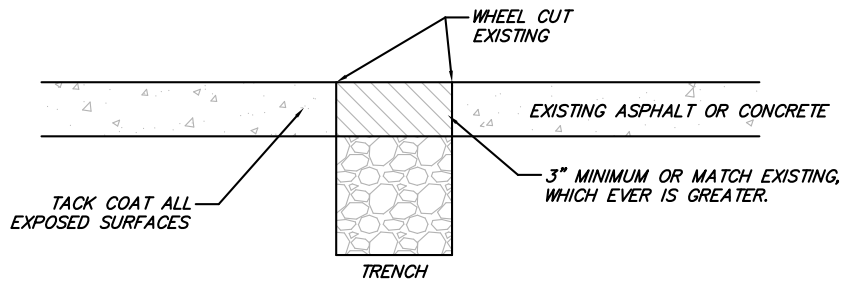

EXISTING ASPHALT CUT & PATCH— POOR STREETS

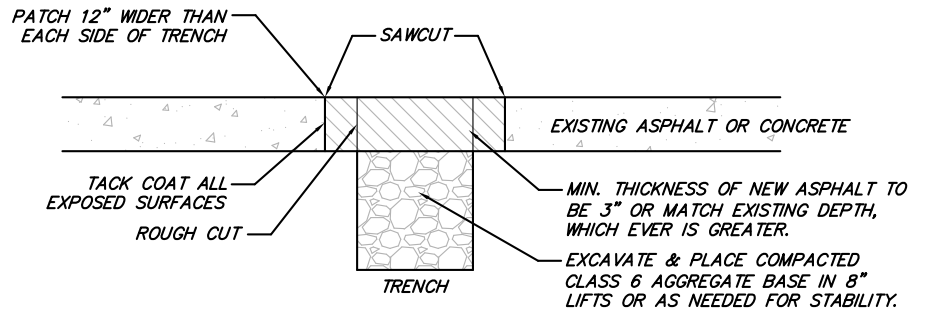

EXISTING ASPHALT CUT & PATCH T-LOCK GOOD STREETS

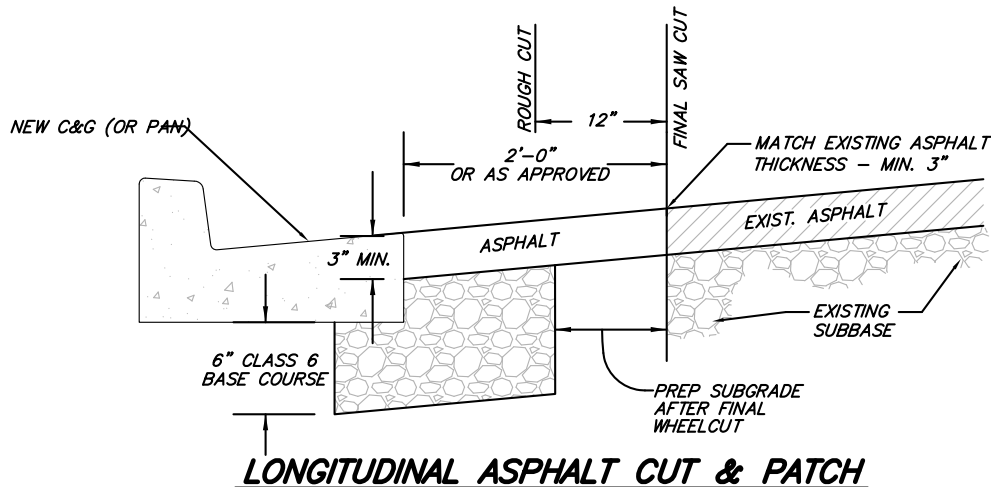

NOTE:

1. MINIMUM THICKNESS OF NEW ASPHALT TO BE 3" OR MATCH EXISTING DEPTH, WHICHEVER IS GREATER.
2. BACKFILL UNDER STREETS - SHALL BE FULL DEPTH CDOT CLASS 6 ROADBASE OR FLOWFILL (FROM NOVEMBER 1ST TO MARCH 15TH) ROADBASE COMPACTED TO 95% STANDARD PROCTOR.
3. PUBLIC WORKS SHALL DETERMINE ROAD CONDITION.
4. THERE SHALL BE NO BORING UNDER CONCRETE CURB & GUTTER, SIDEWALK & STREET. CONCRETE SHALL BE REMOVED AND REPLACED.

DETAIL

TYPICAL ASPHALT PATCHES

CITY OF SALIDA PUBLIC WORKS DEPARTMENT

SCALE

NOT TO SCALE

FILE

DWG: ST-04

LATEST REVISION

6/19/2009

LOCATE CENTER OF STRUCTURE PRIOR TO ASPHALT PLACEMENT. ESTABLISH SUFFICIENT TIES TO RELOCATE CENTER AFTER PAVING

SAWCUT TO OUTSIDE EDGE OF COLLAR

CONTRACTION JOINTS

CONCRETE TO BE 4000PSI W/ FIBER MESH REINFORCEMENT

PROVIDE LIGHT BROOM FINISH. AT COMPLETION CLEAN STRUCTURE & STREET OF ALL EXCESS CONCRETE.

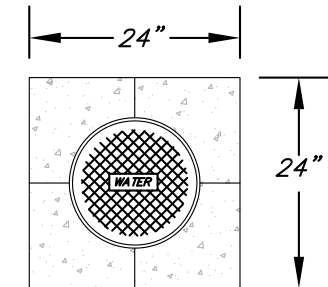
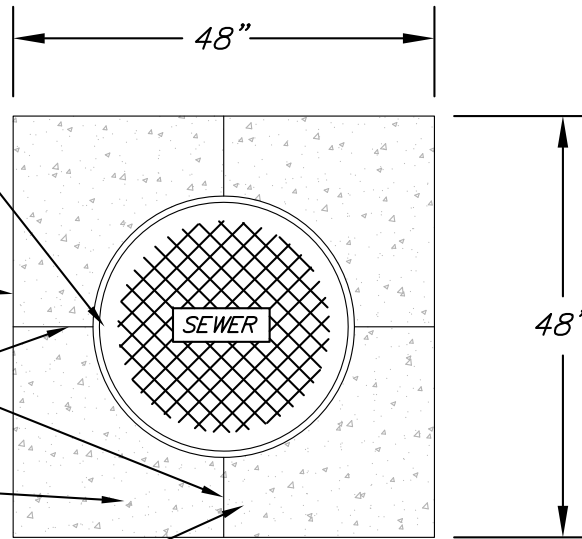

NOTE:
ALL MANHOLE COLLAR NOTES APPLY.

WATER VALVE

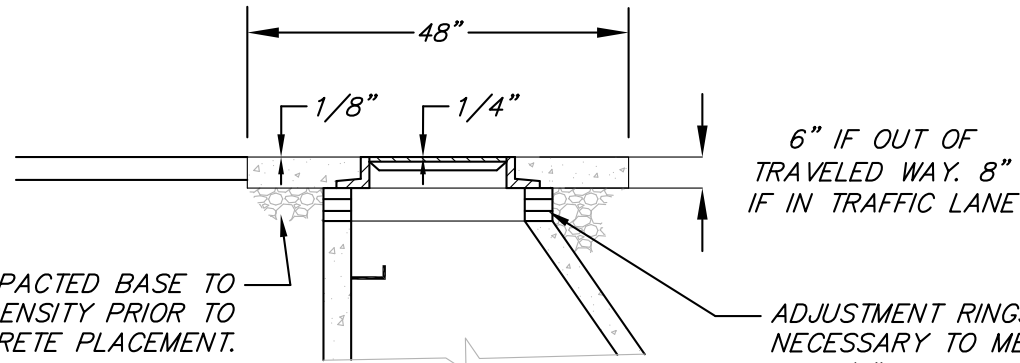

RECOMPACTED BASE TO SPECIFIC DENSITY PRIOR TO CONCRETE PLACEMENT.

6" IF OUT OF TRAVELED WAY. 8" IF IN TRAFFIC LANE

ADJUSTMENT RINGS - RAISE AS NECESSARY TO MEET FINISH GRADE OF 1/4" BELOW CONCRETE. (MANHOLES & WATER VALVES)

DETAIL

CONCRETE COLLAR DETAILS

CITY OF SALIDA PUBLIC WORKS DEPARTMENT

SCALE
NOT TO SCALE

SCALE
DWG: ST-05

LATEST REVISION
6/19/2009

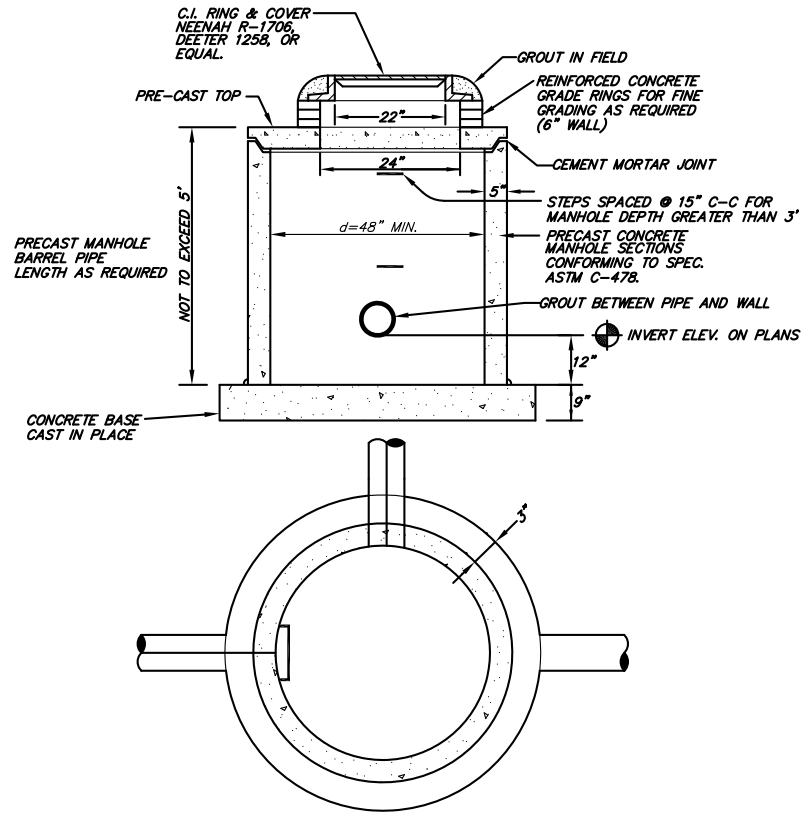

NOTES:

1. PRECAST RINGS OR METAL RISER RING COURSE SHALL BE UTILIZED WHERE REQUIRED WITH 2 COURSES MINIMUM AND 6 COURSES MAXIMUM (1" MINIMUM, 6" MAXIMUM HEIGHT).
2. WHERE AVAILABLE FROM PIPE MANUFACTURER, USE EXPANDABLE WATER STOP OR SPECIAL SLEEVE AS PER MANUFACTURER'S SPECIFICATIONS.
3. ALL BASES SHALL BE CAST IN PLACE OR PRECAST CONCRETE; USE #4 REBAR ON 12" C-C BOTH WAYS IN POURED BASES.
4. SET EACH RING IN A FULL BED OF MORTAR AND GROUT ALL INSIDE JOINTS WITH PREFORMED GASKET MATERIAL.

STORM DRAIN MANHOLE DETAIL

N.T.S.

DETAIL

STORM DRAIN
MANHOLE

CITY OF SALIDA PUBLIC WORKS DEPARTMENT

SCALE

NOT TO SCALE

FILE

DWG: SD-01

LATEST REVISION

6/19/2009

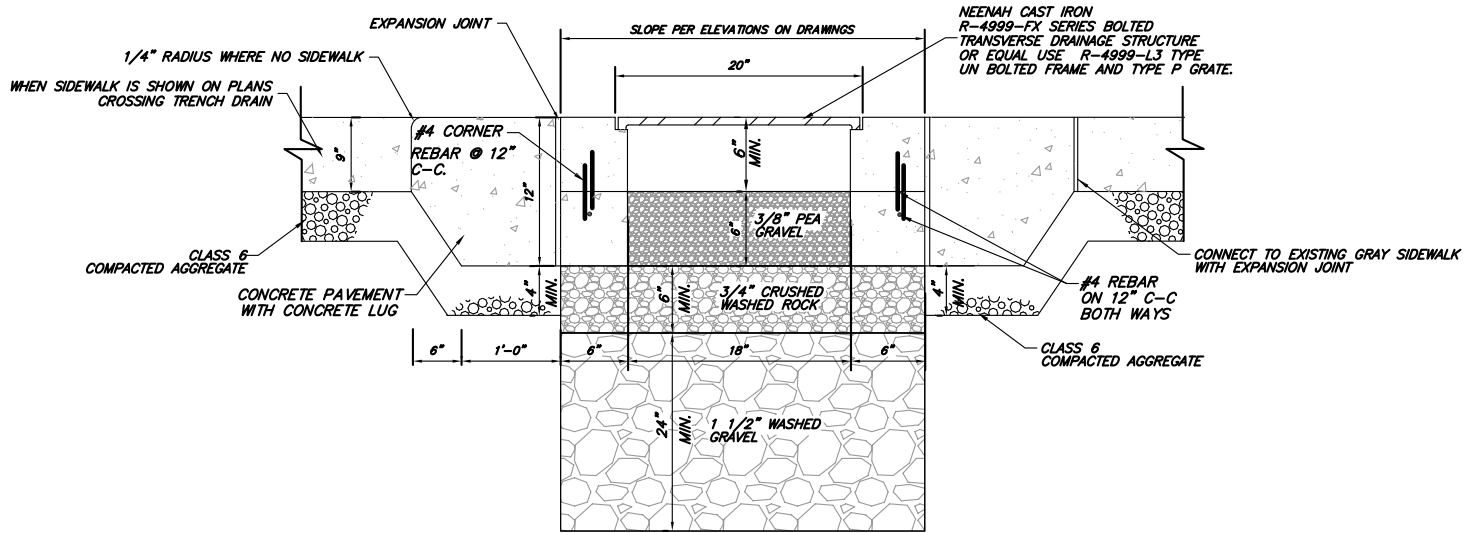

**CONCRETE TRENCH DETAIL
WITH INFILTRATION DITCH**

N.T.S.

NOTE*
1) TRENCH DRAIN INFILTRATION DITCH TO BE DESIGNED BASED ON DRAINAGE ANALYSIS, SUBMIT PROFESSIONAL ENGINEERS STAMPED DESIGN DRAWINGS AND REPORT TO THE CITY PUBLIC WORKS DEPARTMENT FOR APPROVAL.

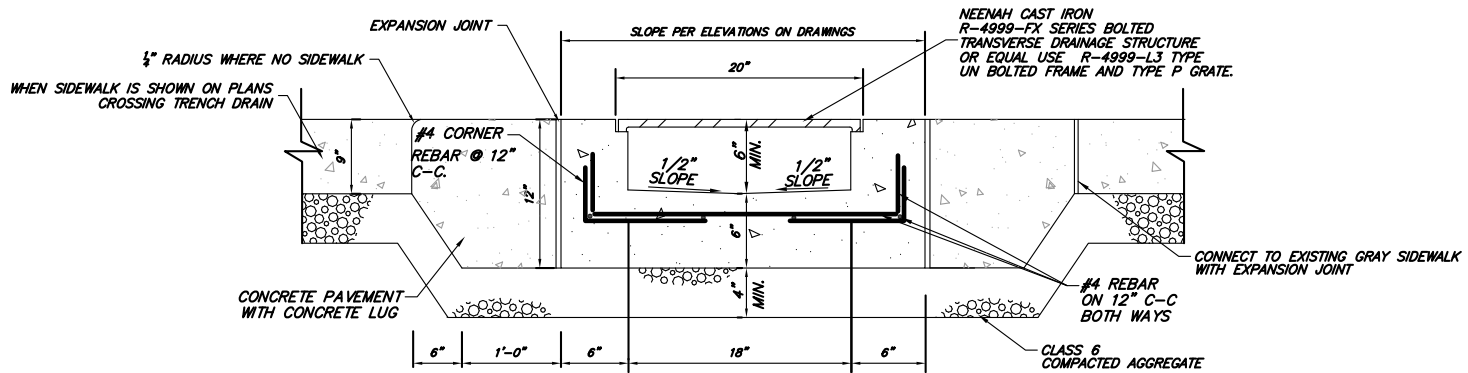

**CONCRETE TRENCH DETAIL
CONCRETE BOTTOM**

N.T.S.

DETAIL

TRENCH DRAIN
DETAIL

CITY OF SALIDA PUBLIC WORKS DEPARTMENT

SCALE
NOT TO SCALE

FILE
DWG: SD-02

LATEST REVISION
6/19/2009

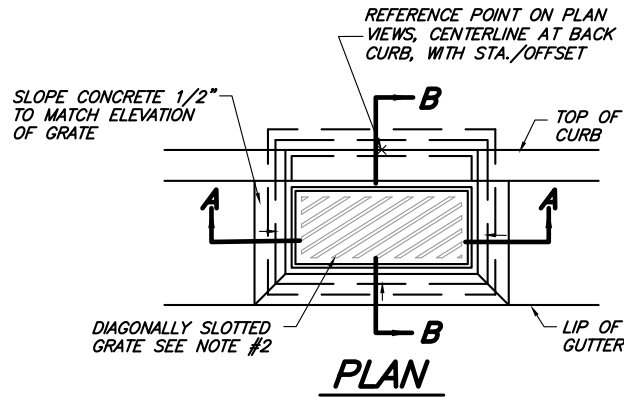

NOTES:

- 1) FRAME, GRATE & CURB INLET TO BE DEETER FOUNDRY, INC. #2046 OR APPROVED EQUAL.
- 2) DOUBLE INLET FRAME, GRATE & CURB INLET TO BE DEETER FOUNDRY, INC. #2046 OR APPROVED EQUAL. (ABUTTING SIDE FLANGES TO BE OMITTED TO FORM DOUBLE). THE CONCRETE BASIN FOR THE DOUBLE INLET SHALL BE THE SAME AS SHOWN, EXCEPT THAT THE OVERALL WIDTH OF SECTION A-A SHALL BE 6'-10" RATHER THAN 3'-8".
- 3) FRAME & GRATE SHALL BE DUCTILE IRON AND SIZED PER DRAINAGE ANALYSIS AND LOADING.
- 4) PRECAST CONCRETE ADJUSTMENT RINGS (IF REQUIRED) SHALL BE GROUTED IN PLACE.
- 5) PIPE ENDS ARE TO BE TRIMMED FLUSH WITH THE INTERIOR WALLS.
- 6) SET GRATE W/ CONC. LEVELING COURSE TO MATCH LONGITUDINAL SLOPE OF THE ROAD.

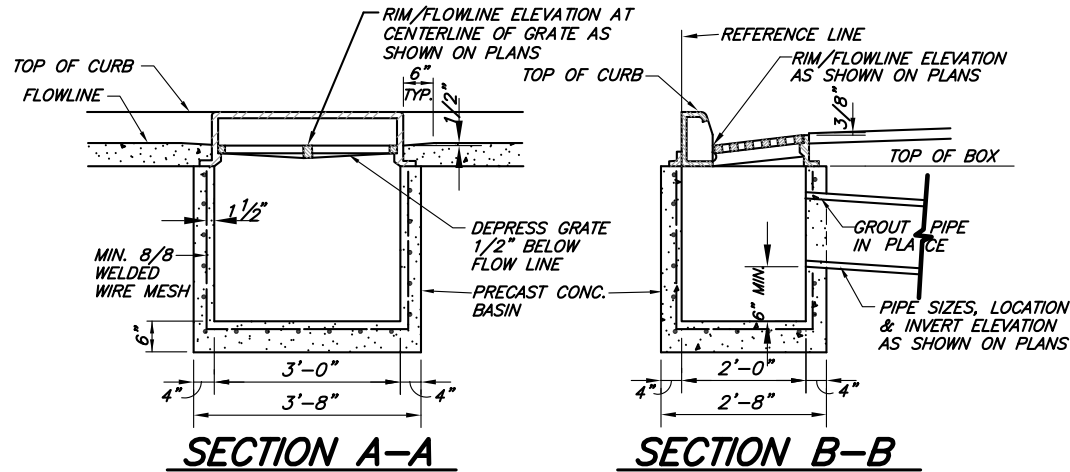

DRAIN INLET

SCALE: 1/2" = 1'-0"

DETAIL

CURB INLET

CITY OF SALIDA PUBLIC WORKS DEPARTMENT

SCALE
NOT TO SCALE

FILE
DWG: SD-03

LATEST REVISION
6/19/2009

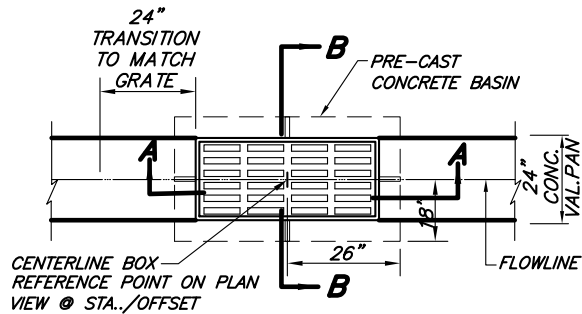

PLAN

NOTES:

- 1) CATCH BASIN INLET GRATE & FRAME TO BE DEETER FOUNDRY, INC. 2501 OR APPROVED EQUAL.
- 2) FRAME & GRATE SHALL BE ASPHALT PAINT-DIPPED BY MANUFACTURER.
- 3) PRECAST CONCRETE ADJUSTMENT RINGS (IF REQUIRED) SHALL BE GROUTED IN PLACE.
- 4) PIPE ENDS ARE TO BE TRIMMED FLUSH WITH THE INTERIOR WALLS.
- 5) SET GRATE W/ CONC. LEVELING COURSE TO MATCH LONGITUDINAL SLOPE OF THE ROAD.

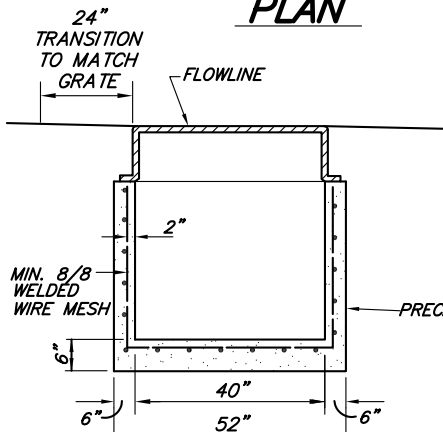

SECTION A-A

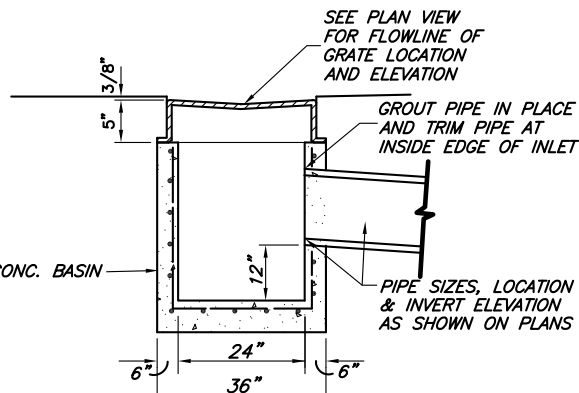

SECTION B-B

VALLEY PAN DRAIN INLET DETAIL

NOT TO SCALE

DETAIL

VALLEY PAN
INLET

CITY OF SALIDA PUBLIC WORKS DEPARTMENT

SCALE

NOT TO SCALE

FILE

DWG: SD-04

LATEST REVISION

6/19/2009

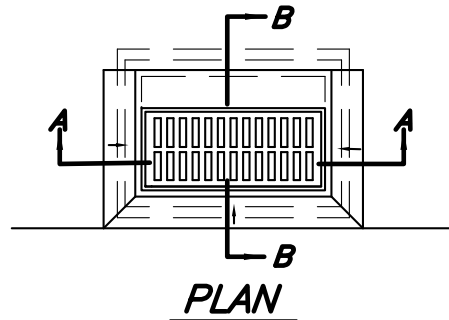

NOTES:

- 1) FRAME & GRATE TO BE NEENAH FOUNDRY INC. R-3382 OR APPROVED EQUAL.
- 2) FRAME & GRATE SHALL BE ASPHALT PAINT-DIPPED BY MANUFACTURER.
- 3) PRECAST CONCRETE ADJUSTMENT RINGS (IF REQUIRED) SHALL BE GROUTED IN PLACE.
- 4) PIPE ENDS ARE TO BE TRIMMED FLUSH WITH THE INTERIOR WALLS.

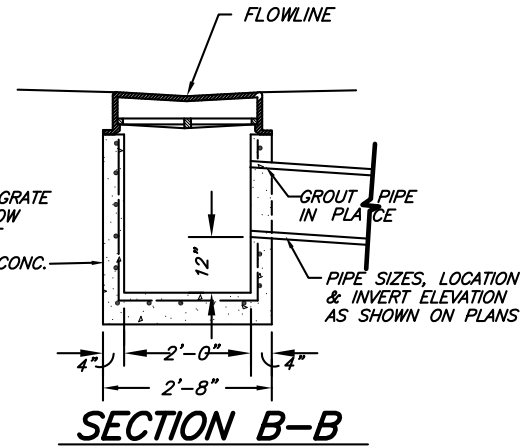
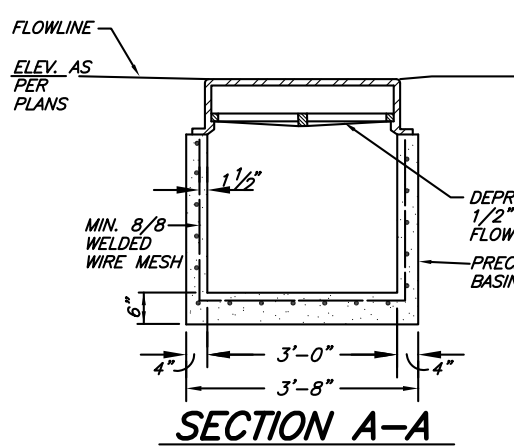

TYPE 13 INLET

SCALE: 1/2" = 1'-0"

DETAIL

AREA DRAIN

CITY OF SALIDA PUBLIC WORKS DEPARTMENT

SCALE
NOT TO SCALE

FILE
DWG: SD-05

LATEST REVISION
6/19/2009

City of Salida, Colorado
Department of Public Works

WATER and SEWER CONSTRUCTION STANDARDS

TABLE OF CONTENTS

WATER

W-01	Typical Meter Installation
W-02	Standard Water Meter
W-03	1 ½ " and UP Meter and Vault
W-04	Fire Hydrant
W-05	Flushing Hydrant
W-06	Meter Pit in Concrete
W-07	Thrust Block Details

SANITARY SEWER

SS-01	Standard Manhole
SS-02	Drop Manhole
SS-03	Cast Iron Manhole Ring and Cover

MISCELLANEOUS

WS-01	Water and Sewer Line Crossings
WS-02	Ditch Crossing

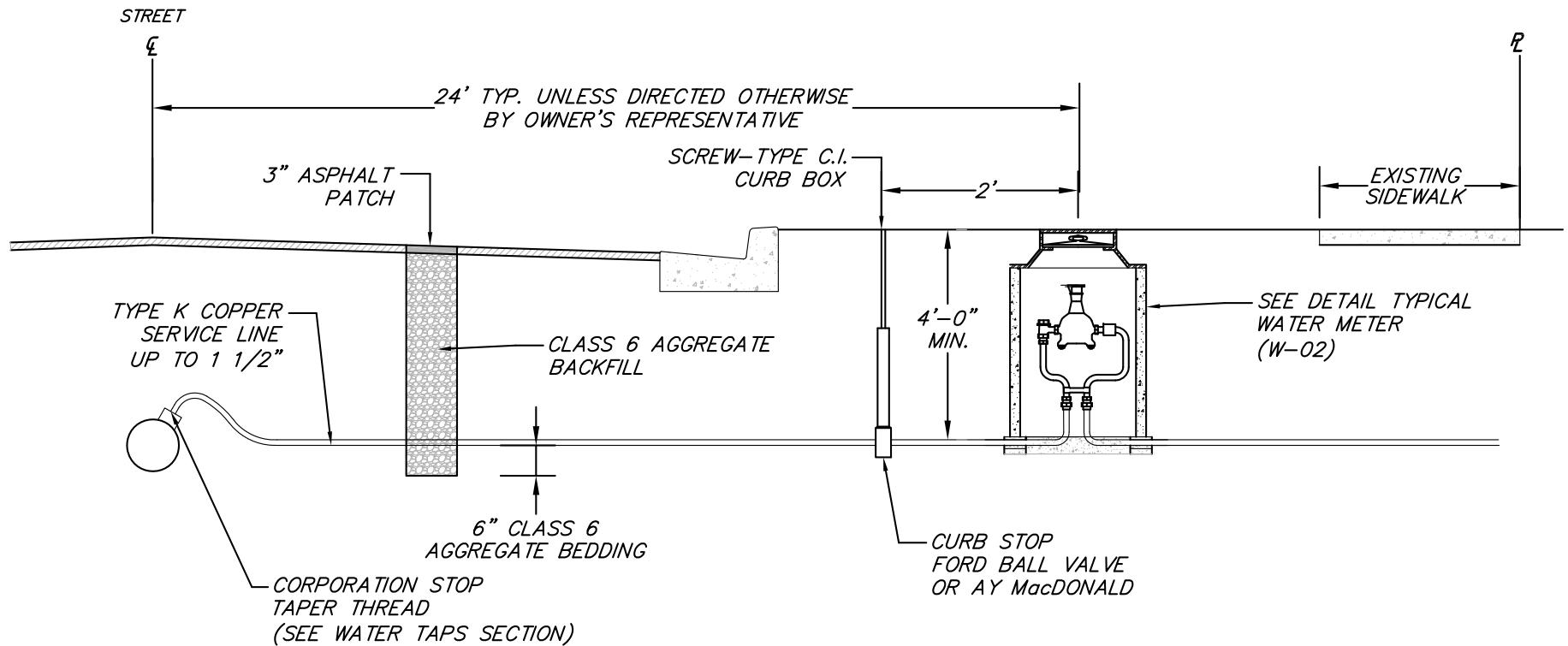

DETAIL

TYPICAL METER INSTALLATION

CITY OF SALIDA PUBLIC WORKS DEPARTMENT

SCALE

NOT TO SCALE

FILE

DWG: W-01

LATEST REVISION

6/19/2009

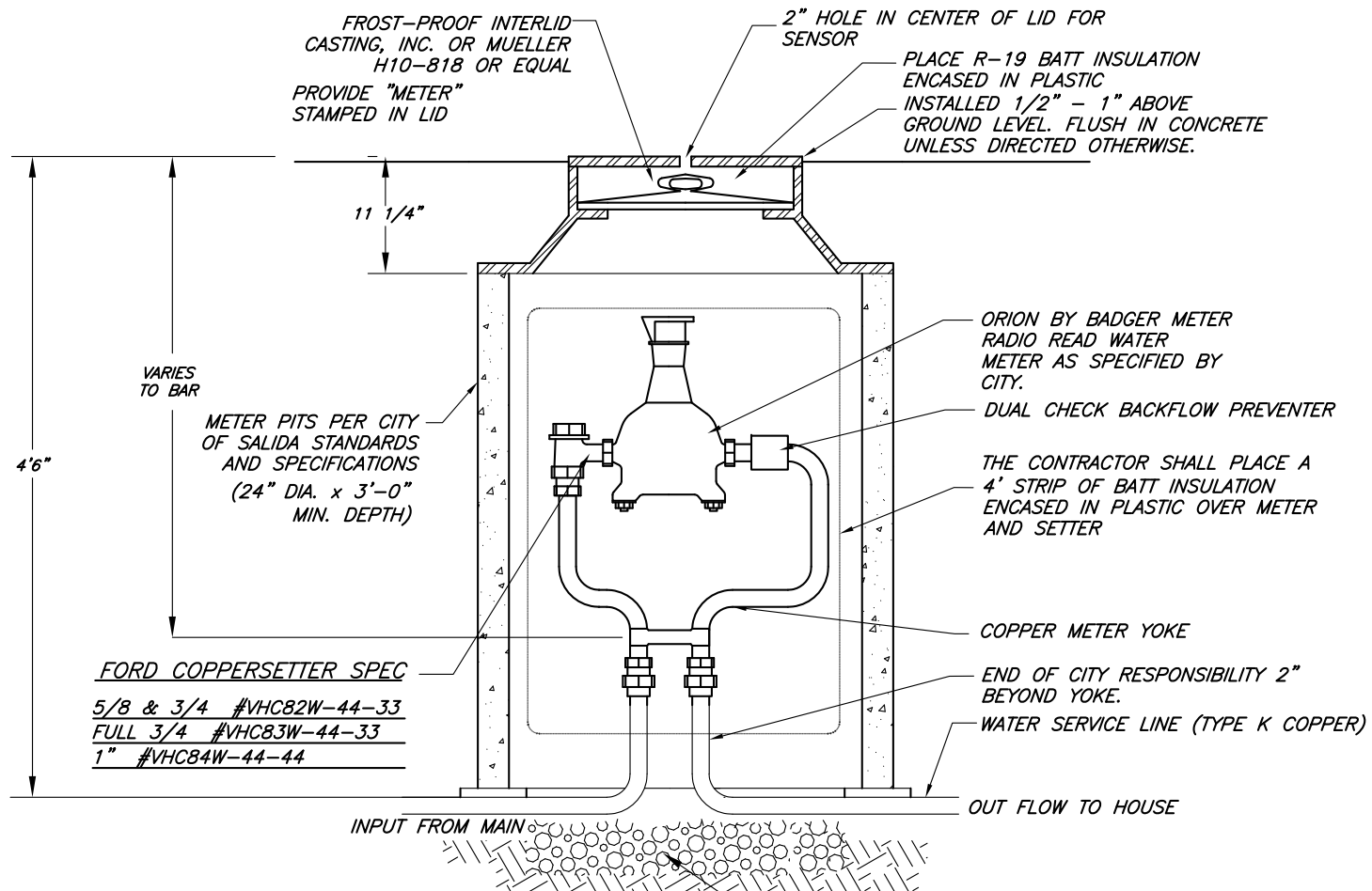

***NOTES:**

1. THERMAL-COIL METER BOXES
ALLOWED AFTER JANUARY 2010
APPROVED MANUFACTURES
MUELLER/HUNT, FORD, AY McDONALD

2. A PRESSURE REDUCING VALVE
SHOULD BE INSTALLED IF STATIC LINE
PRESURE EXCEEDS 70 PSI. PRV
INSTALLED IN CRAWL SPACE OR AREA
OF HOME NOT IN METER PIT.

6" OF 3/4" SCREENED ROCK OR CLASS 6
ROADBASE, BELOW PIPE; PLACE ROCK TO
MIDPOINT OF PIPE. (CDOT TYPE 2 CHIPS)

METER SIZE	DEPTH
5/8"	22"
3/4"	24"
1"	26"

<p>DETAIL</p> <p>TYPICAL METER SETTING DETAIL</p>	<p>CITY OF SALIDA PUBLIC WORKS DEPARTMENT</p>		
	<p>SCALE</p> <p>NOT TO SCALE</p>	<p>FILE</p> <p>DWG: W-02</p>	<p>LATEST REVISION</p> <p>6/19/2009</p>

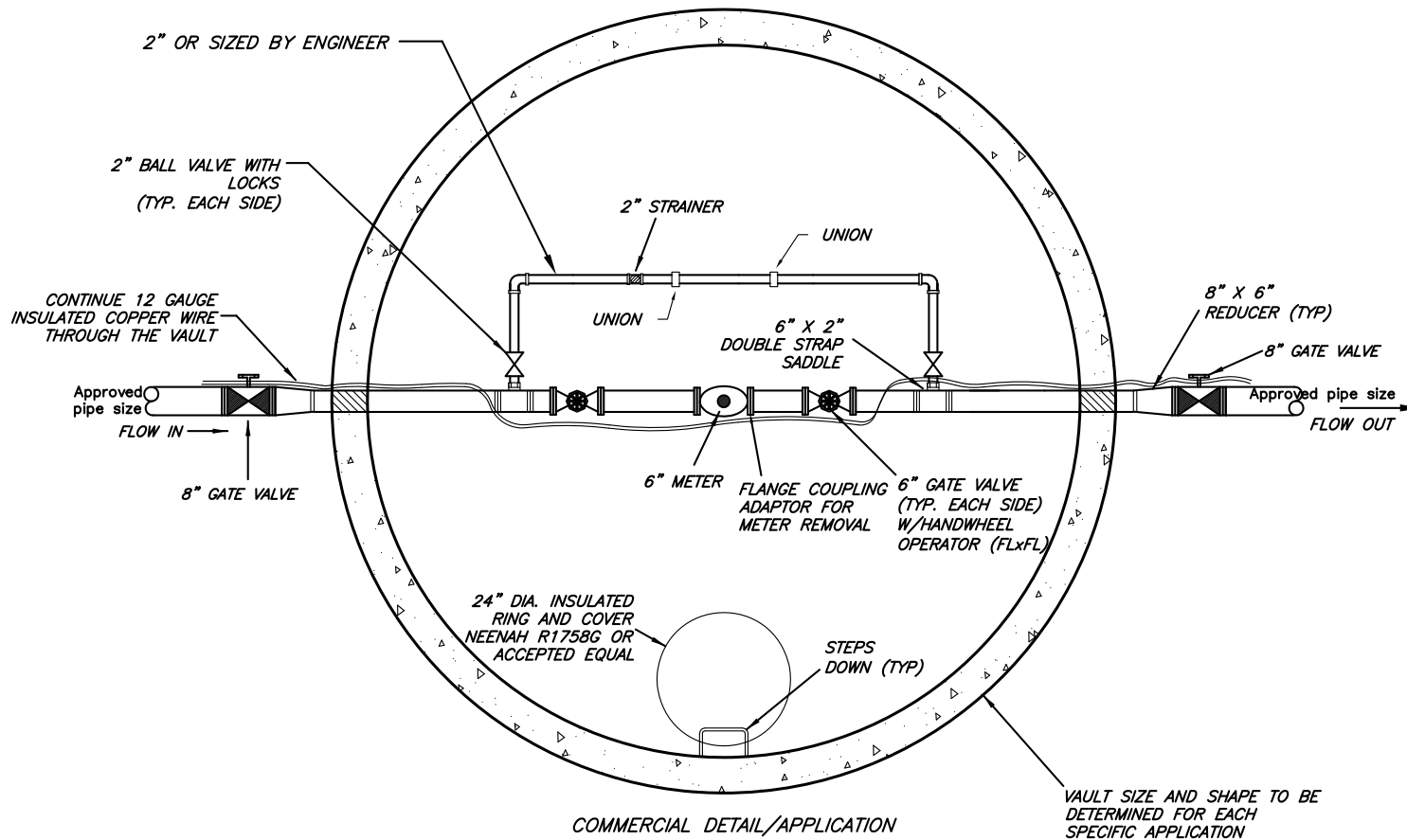

PLAN

NOTES

1. VAULT SHALL BE PRECAST CONCRETE AND CAPABLE OF WITHSTANDING HS 20-44 TRAFFIC LOADING CONDITIONS
2. WHERE PIPES PENETRATE WALLS, USE LINK SEAL OR FILL ANNULAR SPACE W/ NON-SHRINK GROUT
3. COAT ALL EXTERIOR VAULT SURFACES WITH BITUMINOUS DAMPROOFING
4. ALL 2" PIPE SHALL BE BRASS OR GALVANIZED.
5. ALL TIE-RODS SHALL BE 3/4" ALL-THREAD OR MEGA-LUGS ON EXTERIOR CONNECTIONS
6. CONTRACTOR SHALL SUBMIT VAULT PIPING SCHEMATIC W/ VAULT DIMENSIONS TO PUBLIC WORKS PRIOR TO ORDERING MATERIALS OR EQUIPMENT

DETAIL

4" & UP WATER METER
AND VAULT DETAIL

CITY OF SALIDA PUBLIC WORKS DEPARTMENT

SCALE
NOT TO SCALE

FILE
DWG: W-03

LATEST REVISION
6/19/2009

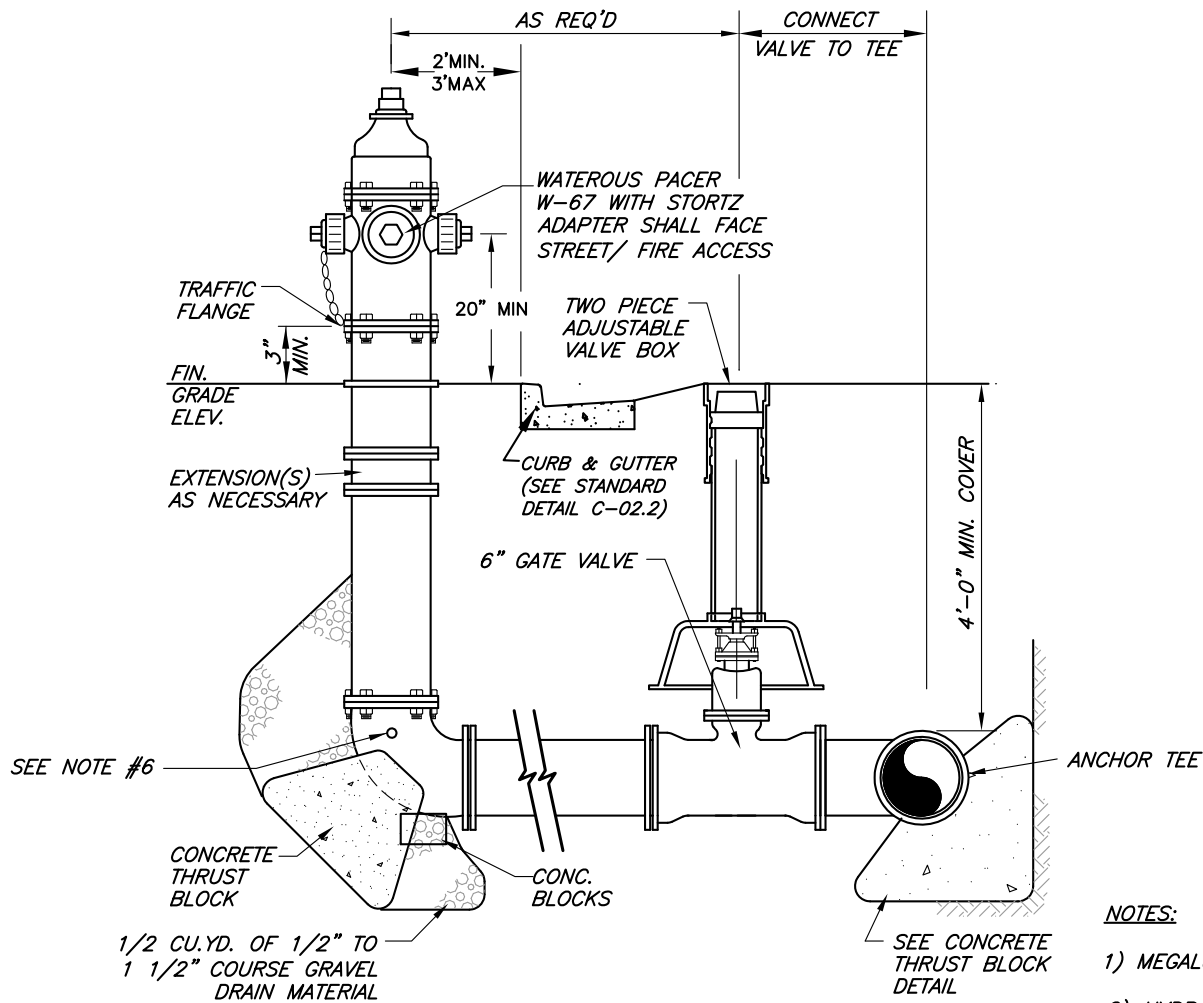

NOTES:

- 1) MEGALUGS TO BE USED FOR ALL MECHANICAL JOINTS
- 2) HYDRANT, VALVE AND FITTINGS TO BE 250 P.S.I. RATED.
- 3) POLYETHYENE WRAP SHALL COVER D.I.P. ASSEMBLY FROM HYDRANT BASE TO WATER MAIN IF CORROSIVE SOILS ARE PRESENT.
- 4) ALL HYDRANT LEAD PIPING TO BE 6" OR LARGER D.I.P.
- 5) CENTERLINE OF HYDRANT TO BE 2'-0" FROM BACK OF CURB UNLESS OTHERWISE NOTED.
- 6) CARE SHOULD BE TAKEN TO ASSURE THAT WEEP HOLE REMAINS FREE DRAINING, AND THE DRAIN WATER HAS CLEAR PATH TO THE DRAIN ROCK.

DETAIL

FIRE HYDRANT SETTING DETAIL

CITY OF SALIDA PUBLIC WORKS DEPARTMENT

SCALE

NOT TO SCALE

FILE

DWG: W-04

LATEST REVISION

6/19/2009

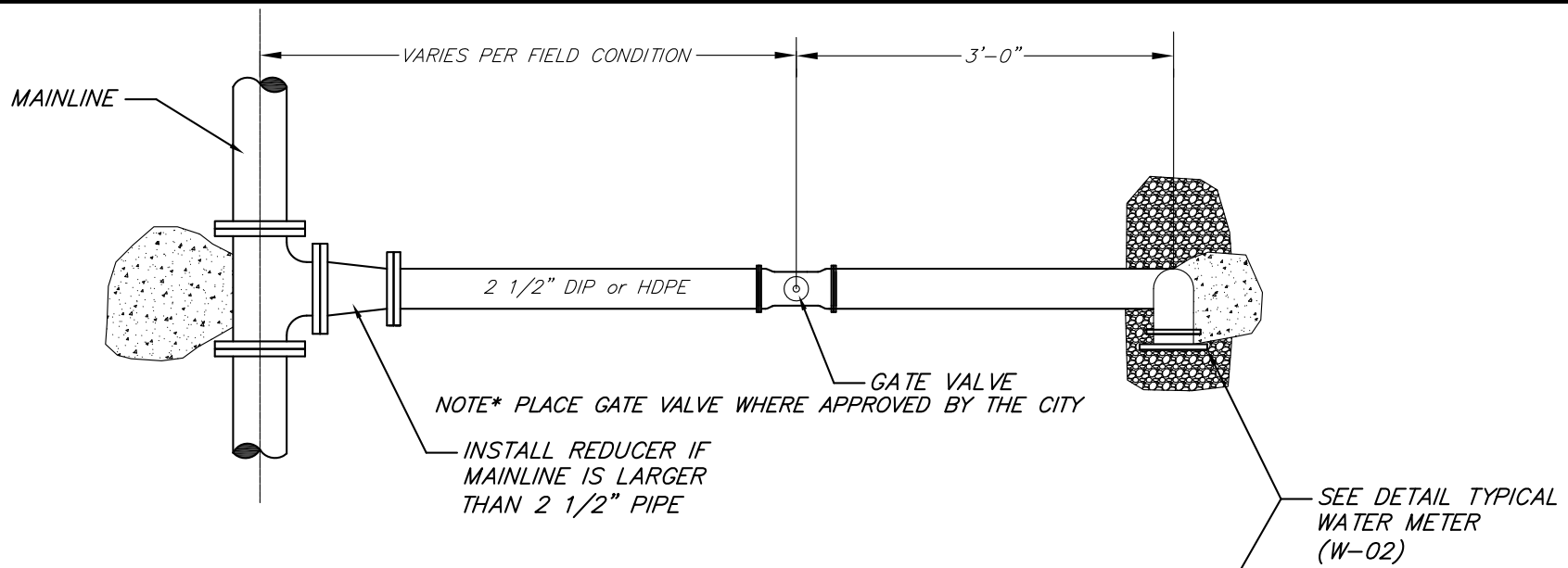

NOTE*
PLACE GATE VALVE WHERE APPROVED BY THE CITY

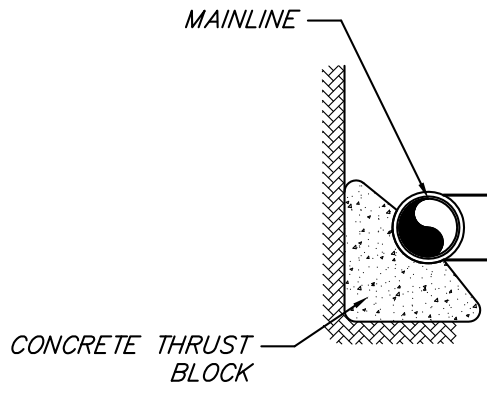
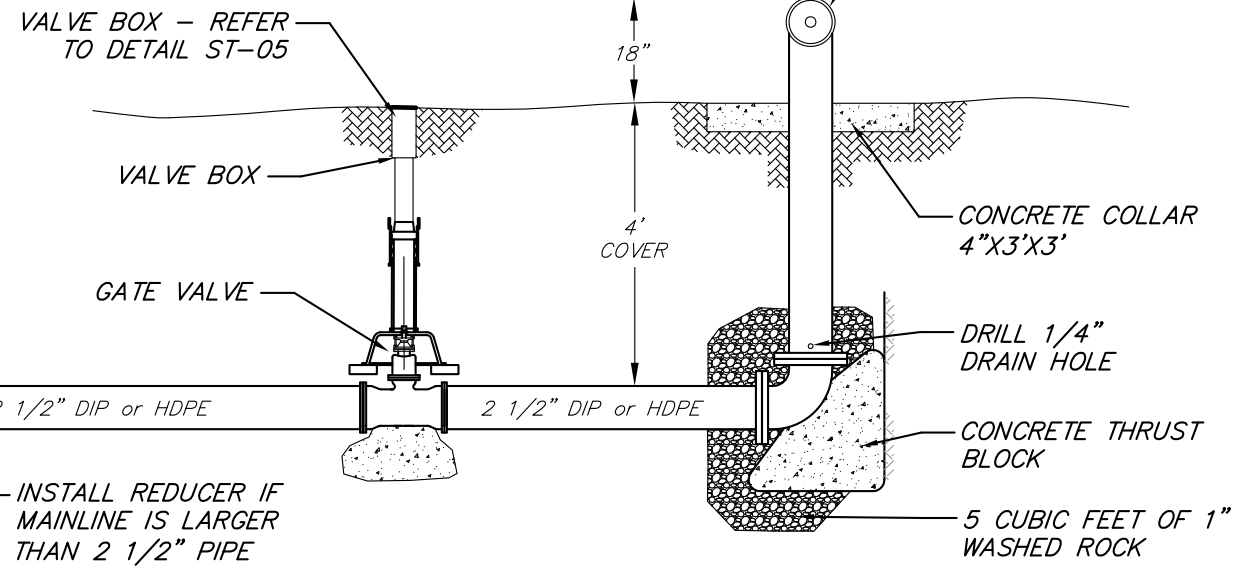

DETAIL <h1 style="margin: 0;">FLUSHING HYDRANT</h1>	<h2 style="margin: 0;">CITY OF SALIDA PUBLIC WORKS DEPARTMENT</h2>		
	SCALE NOT TO SCALE	FILE DWG: W-05	LATEST REVISION 6/19/2009

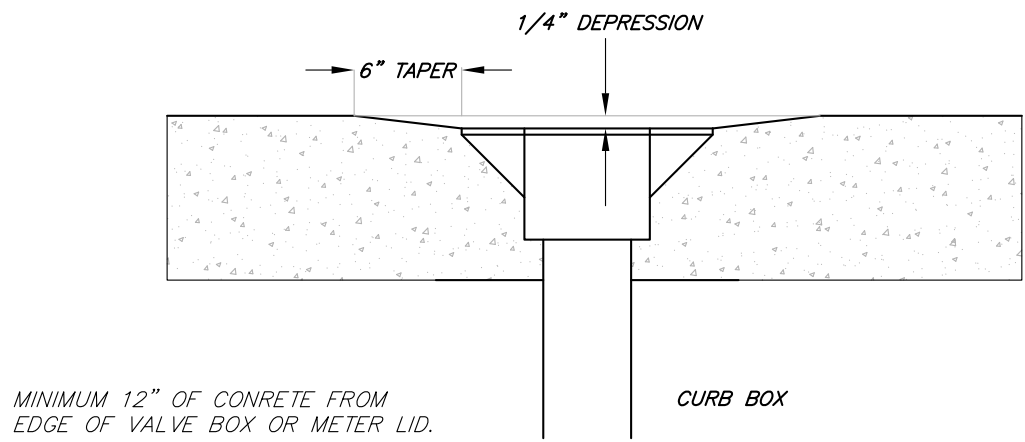
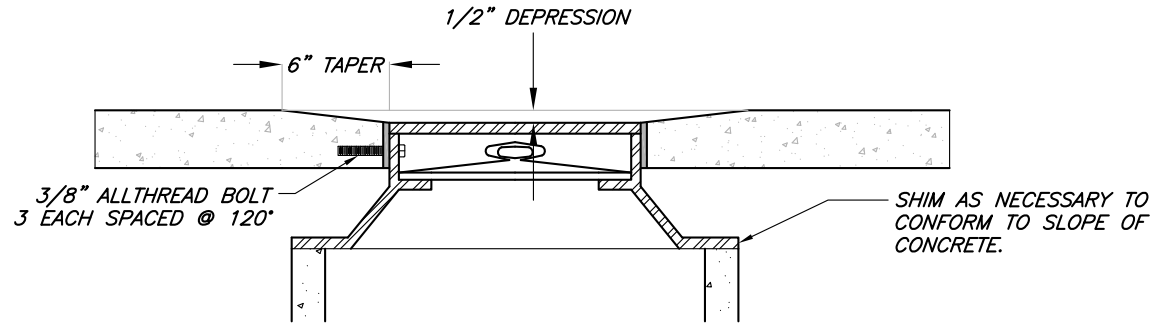

DETAIL

METER PIT IN
CONCRETE

CITY OF SALIDA PUBLIC WORKS DEPARTMENT

SCALE
NOT TO SCALE

FILE
DWG: W-06

LATEST REVISION
6/19/2009

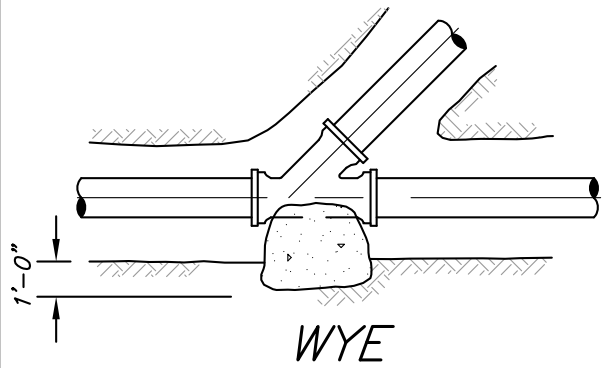

WYE

90°, 45°, 22.5°, OR 11.25°
ELBOW, HORIZONTAL OR
BOTTOM OF VERTICAL

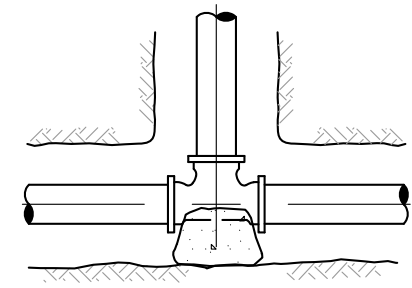
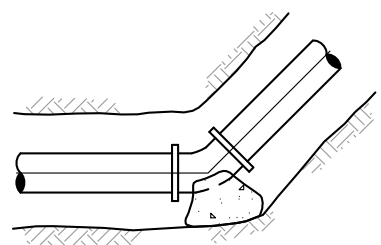

TEE

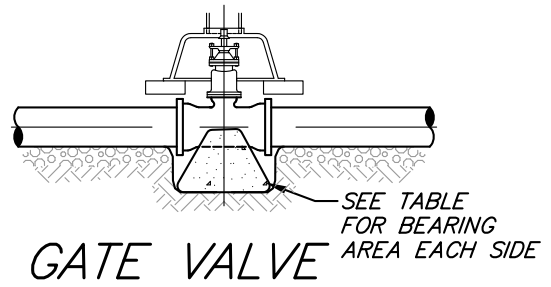

GATE VALVE

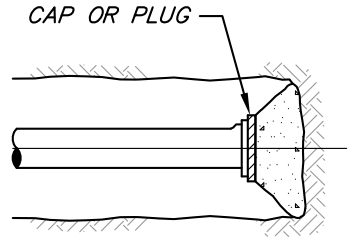

DEAD END

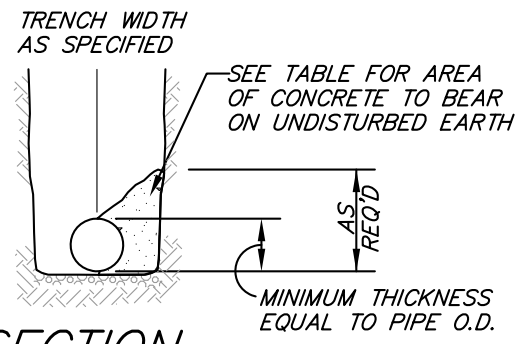

SECTION

NOTES:

1) MEGALUGS ARE REQUIRED ON ALL MECHANICAL JOINTS

2) REACTION BLOCKS ARE REQUIRED ON ALL MECHANICAL JOINTS.

AREAS GIVEN IN TABLE ARE BASED UPON AN INTERNAL STATIC PRESSURE OF 100 P.S.I. AND A SOIL BEARING CAPACITY OF 1000 LBS. PER SQ. FT. BEARING AREAS FOR ANY PRESSURE AND SOIL BEARING CAPACITY MAY BE OBTAINED BY MULTIPLYING THE TABULATED VALUES BY A CORRECTION FACTOR "F".

F = $\frac{\text{ACTUAL SPECIFIED TEST PRESSURE IN HUNDREDS OF LBS.}}{\text{ACTUAL SOIL BEARING CAPACITY IN THOUSANDS OF LBS. PER SQ. FT.}}$

INSTALLATION OF THRUST BLOCKS ARE NOT ALLOWED FOR CONDITIONS OUTSIDE OF THOSE LISTED UNTIL SUBMITTAL OF CALCULATIONS FOR THE CORRECTION FACTOR ARE SUBMITTED TO AND REVIEWED BY THE TOWN AND WRITTEN APPROVAL BY THE TOWN IS GIVEN.

SIZE (INCHES)	ELBOWS				TEES & DEAD ENDS (SQ. FT.)	GATE VALVES (SQ. FT.)
	90° (SQ. FT.)	45° (SQ. FT.)	22.5° (SQ. FT.)	11.25° (SQ. FT.)		
4	1.8	1.0	0.5	0	1.3	0.5
6	4.0	2.2	1.1	0	2.8	0.7
8	7.1	3.8	2.0	1.0	5.0	2.4
10	11.1	6.0	3.0	1.5	7.8	4.5
12	16.0	8.6	4.4	2.2	11.3	7.3
14	21.7	11.8	6.0	3.0	15.4	11.0
16	28.4	15.3	8.0	4.0	20.0	16.6
18	36.0	19.4	10.0	5.0	25.4	24.9

DETAIL

THRUST BLOCKING
DETAILS

CITY OF SALIDA PUBLIC WORKS DEPARTMENT

SCALE NOT TO SCALE	FILE DWG: W-07	LATEST REVISION 6/19/2009
-----------------------	-------------------	------------------------------

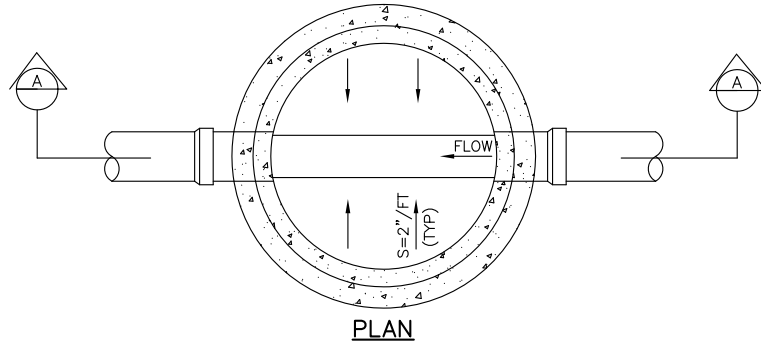
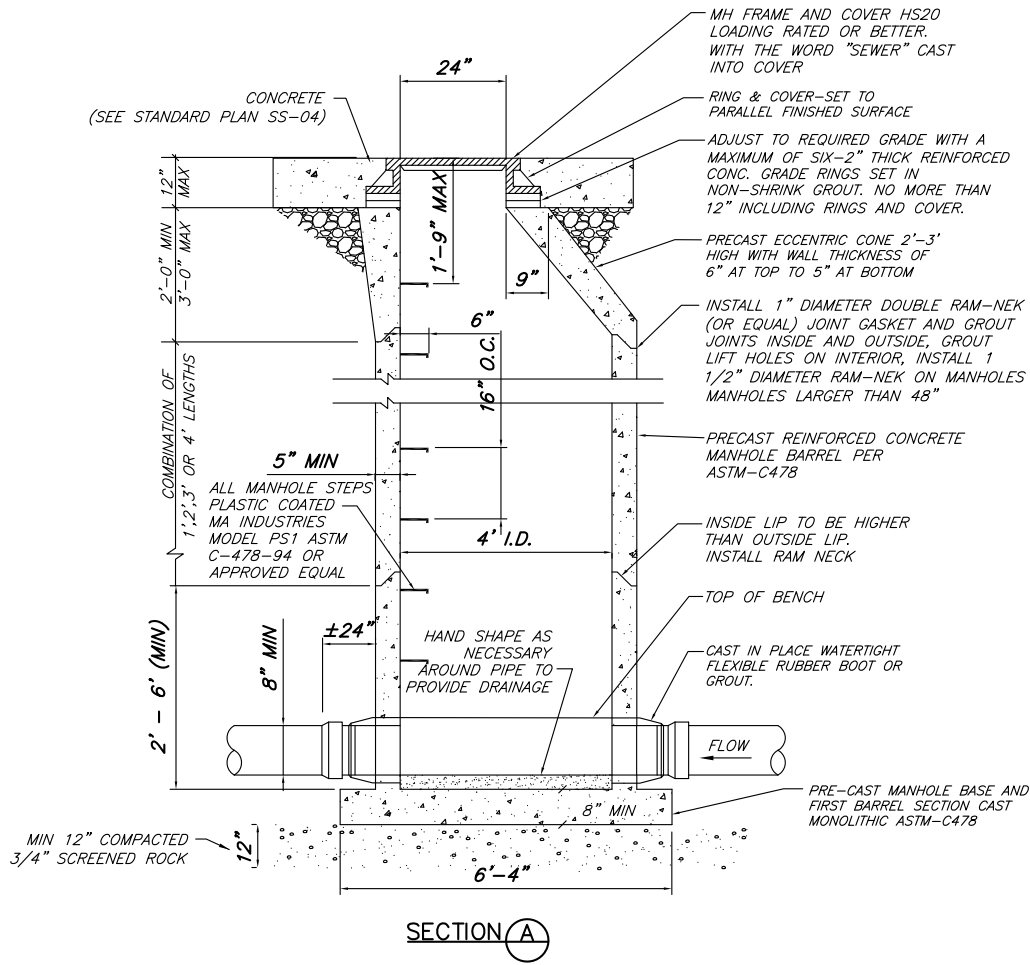

- GENERAL NOTES:
1. ALL CONCRETE WORK SHALL COMPLY WITH LATEST CI-318 SPECIFICATIONS
 2. USE 5' I.D. WHEN PIPE SIZE 15" - 24".
 3. DEPTH OF SEWER INVERT SHALL BE GREATER THAN 4'.

DETAIL <h2 style="margin: 0;">STANDARD SEWER MANHOLE</h2>	<h1 style="margin: 0;">CITY OF SALIDA PUBLIC WORKS DEPARTMENT</h1>		
	SCALE NOT TO SCALE	FILE DWG: SS-01	LATEST REVISION 6/19/2009

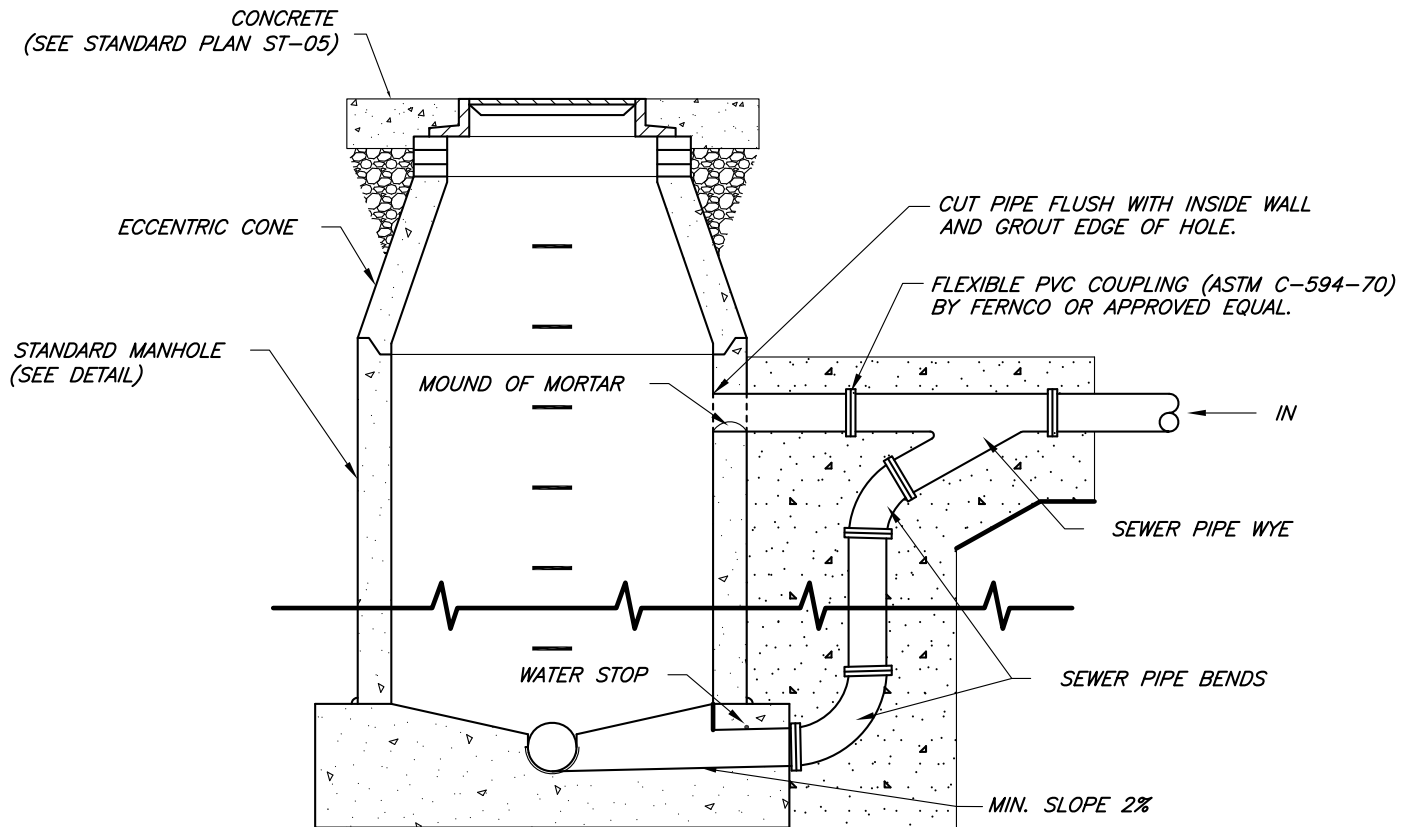

NOTE:
 DROP MANHOLE SHALL BE PROVIDED WHERE
 SEWER ENTERS MH 2'-0" OR MORE ABOVE
 LOWEST INVERT OF MANHOLE.
 SEE DRAWING SS-01 FOR MANHOLE DETAILS.

DETAIL

DROP MANHOLE DETAILS

CITY OF SALIDA PUBLIC WORKS DEPARTMENT

SCALE
 NOT TO SCALE

FILE
 DWG: SS-02

LATEST REVISION
 6/19/2009

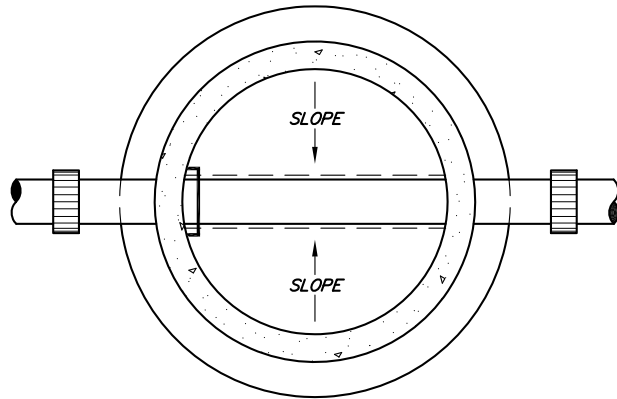

SECTION B - B

NOTES:

1. ALL BASES SHALL BE CAST IN PLACE OR PRECAST CONCRETE; USE #4 REBAR ON 12" C-C BOTH WAYS IN POURED BASES.
2. PIPE JOINT TO BE LOCATED ON EACH SIDE OF ALL MANHOLES, MAXIMUM OF 24" FROM INSIDE FACE.
3. SEE DRAWING SS-01 FOR MANHOLE DETAILS.
4. BACKFILL WITHIN 24" OF MANHOLE: CLASS 6 AGGREGATE OR NATIVE MATERIALS WITH LESS THAN 3" SIZE.
5. GRADE ADJUSTMENT AS FOLLOWS: GREATER THAN, OR EQUAL TO, 1 FOOT, CONCRETE BARREL SECTIONS; LESS THAN 10 INCHES, PRE-CAST CONCRETE GRADE RINGS.
6. FINISH GRADE AS FOLLOWS: ASPHALT OR CONCRETE PAVEMENTS 1/4" BELOW GRADE; BASE COURSE SURFACE OR DIRT/TOPSOIL -3" BELOW GRADE. RING & COVER TO MATCH LONGITUDINAL AND CROSS SLOPE OF PAVEMENT.

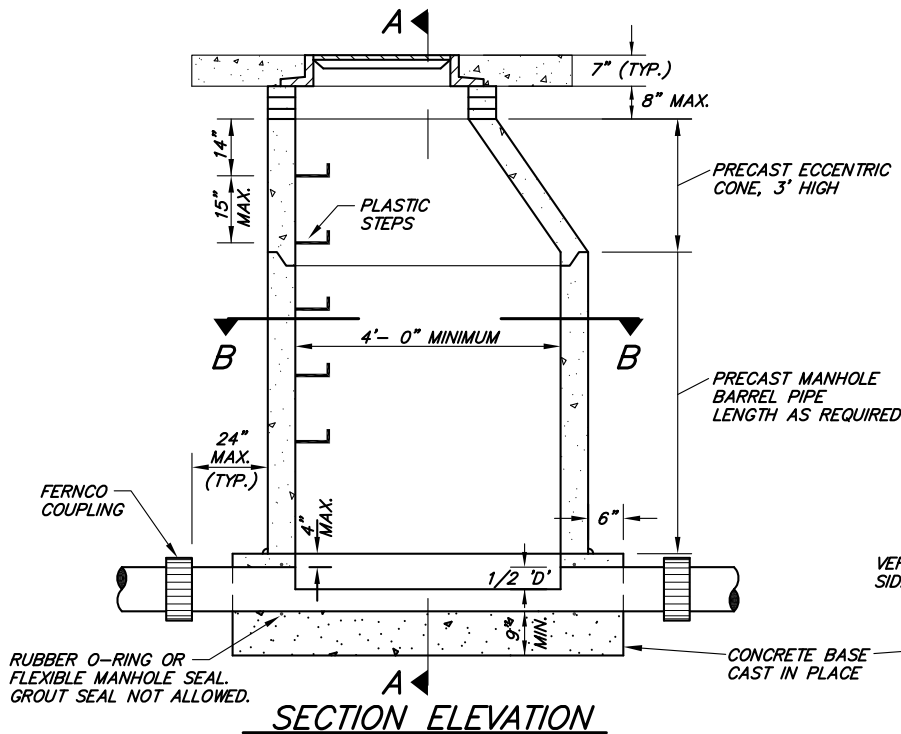

SECTION ELEVATION

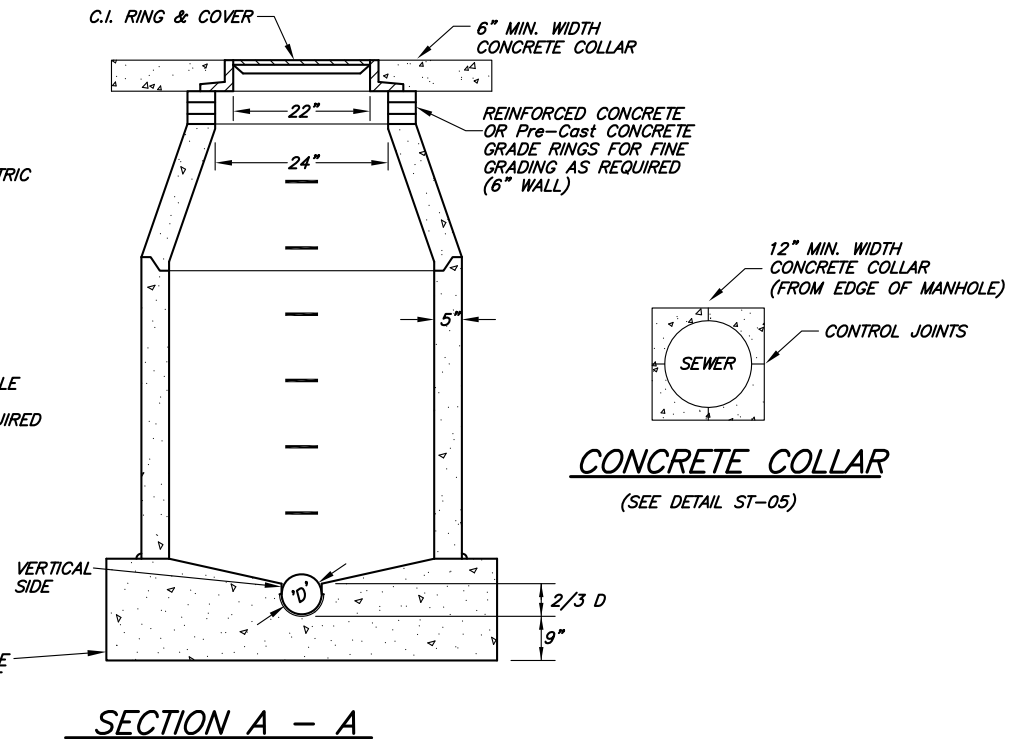

SECTION A - A

CONCRETE COLLAR

(SEE DETAIL ST-05)

DETAIL

CAST IRON MANHOLE RING AND COVER DETAIL

CITY OF SALIDA PUBLIC WORKS DEPARTMENT

SCALE
NOT TO SCALE

FILE
DWG: SS-03

LATEST REVISION
6/19/2009

CONCRETE ENCASEMENT SHALL HAVE
A MINIMUM OF 6" FROM PIPE TO
OUTSIDE EDGE OF CONCRETE

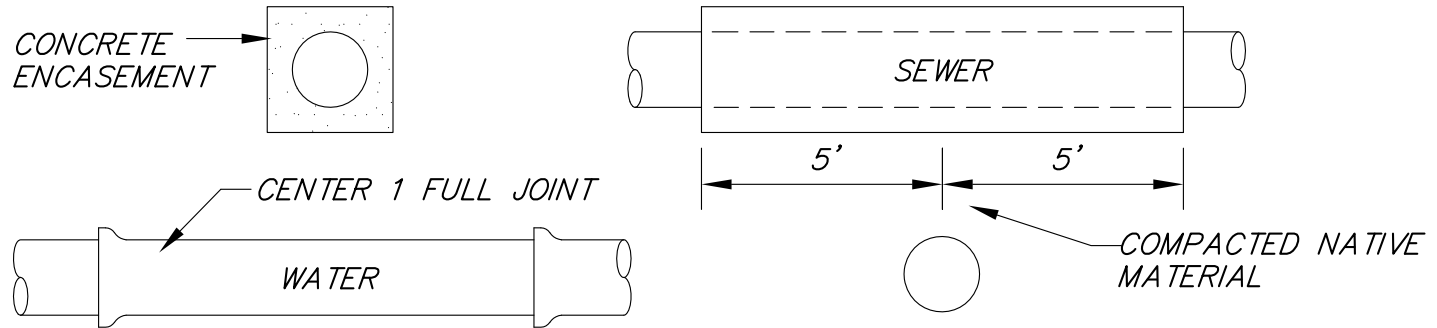

CONDITION #1: NEW WATER MAIN BELOW EXIST. SEWER MAIN

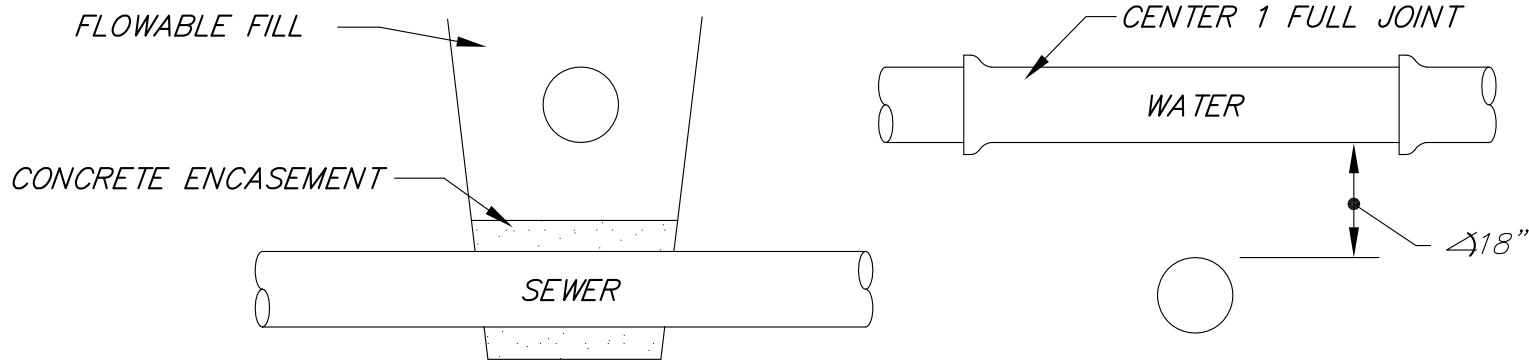

CONDITION #2: NEW WATER MAIN LESS THAN 18" ABOVE EXIST. SEWER MAIN

DETAIL

WATER/SEWER
CROSSING DETAIL

CITY OF SALIDA PUBLIC WORKS DEPARTMENT

SCALE

NOT TO SCALE

FILE

DWG: WS-01

LATEST REVISION

6/19/2009

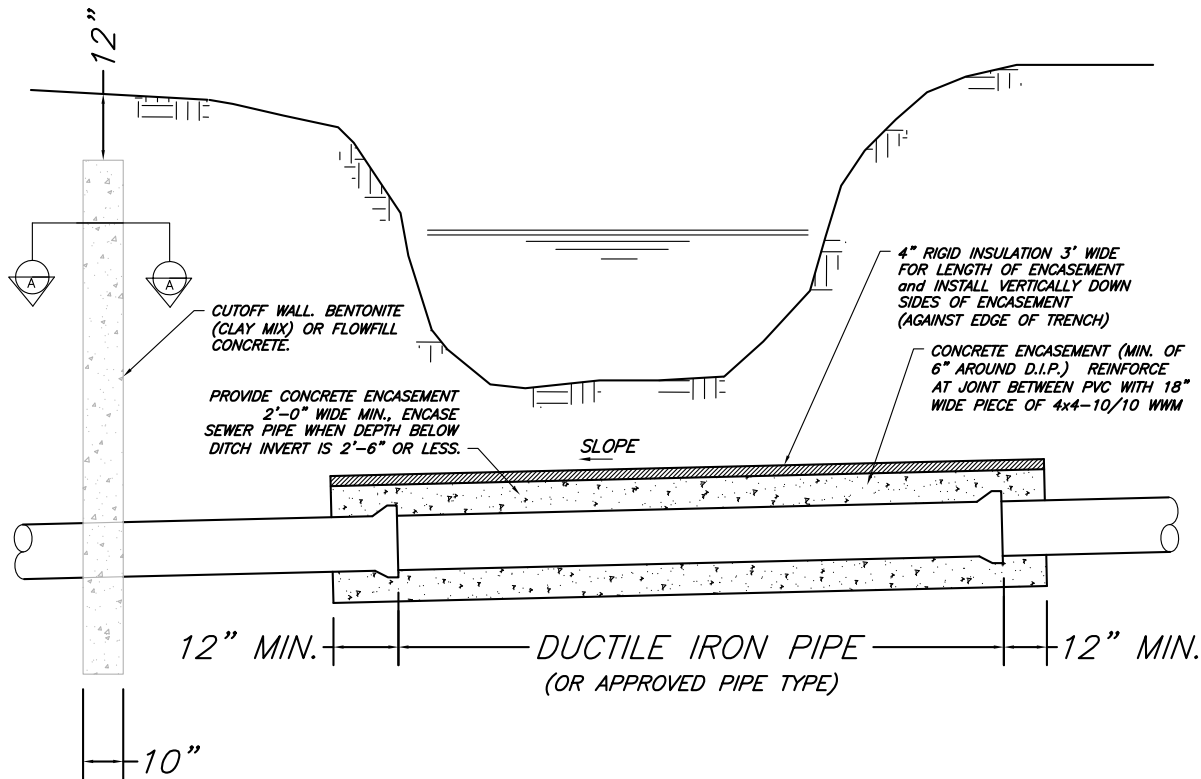

NOTE:

1. WHEN EITHER SIDES OR BOTTOM OF CHANNEL ARE OF GUNITE, CONC. OR MATERIAL OTHER THAN NATURAL SOIL, THE MATERIAL SHALL BE REPLACED IN KIND AFTER CONSTRUCTION OF DITCH CROSSING.
2. RESTORE ALL AFFECTED AREAS TO A CONDITION EQUAL TO OR BETTER THAN EXISTING.
3. COMPACTION OF TRENCH BETWEEN 25' OF EACH SIDE OF DITCH CROSSING SHALL BE 95% MIN. OF STANDARD DENSITY.

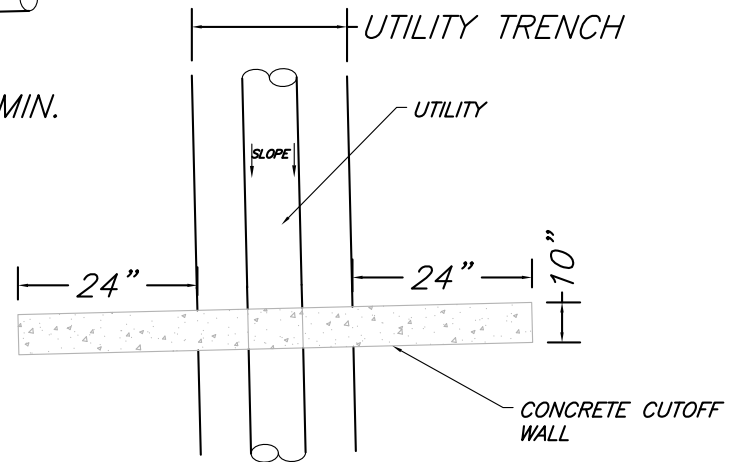

SECTION A-A

DETAIL

DITCH CROSSING
DETAIL

CITY OF SALIDA PUBLIC WORKS DEPARTMENT

SCALE

NOT TO SCALE

FILE

DWG: WS-02

LATEST REVISION

6/19/2009